

GW1114-4DI(RS-485)-TB-P(12-48VDC) Modbus Gateway Quick Installation Guide

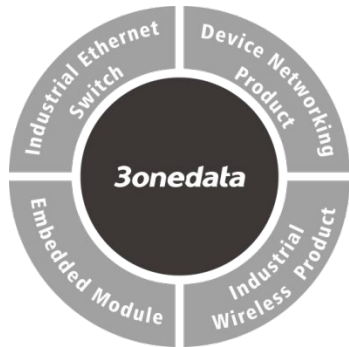

3onedata Co., Ltd.

Address: 3/B, Zone 1, Baiwangxin High Technology Industrial Park, Xili, Nanshan District, Shenzhen

Website: www.3onedata.com

Tel: +86 0755-26702688

Fax: +86 0755-26703485

【Package Checklist】

Please check whether the package and accessories are intact while using the device for the first time.

- | | |
|---------------------------|--------------------|
| 1. Modbus Gateway | 2. Mounting lug x2 |
| 3. Power adapter | 4. Foot pad x4 |
| 5. Straight-through cable | 6. Warranty card |
| 7. Certificate | |

If any of these items are damaged or lost, please contact our company or dealers, we will solve it ASAP.

【Product Overview】

The product is desktop/wall-mounting Modbus gateway. The model is GW1114-4DI(RS-485)-TB-P(12-48VDC) (2 100M copper ports + 4 RS-485 serial ports with single-port isolation + 1 12~48VDC power supply).

【Panel Design】

➤ Front view

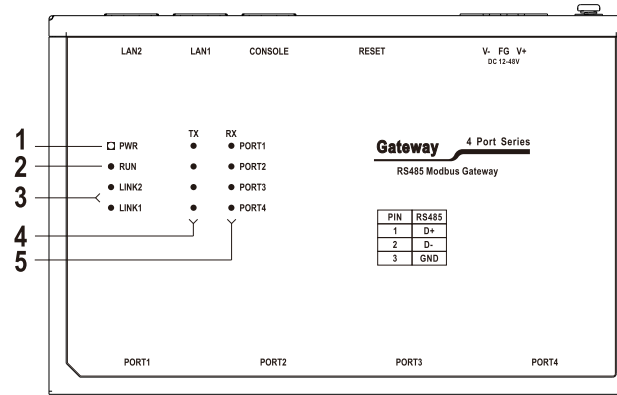

➤ Top view and bottom view

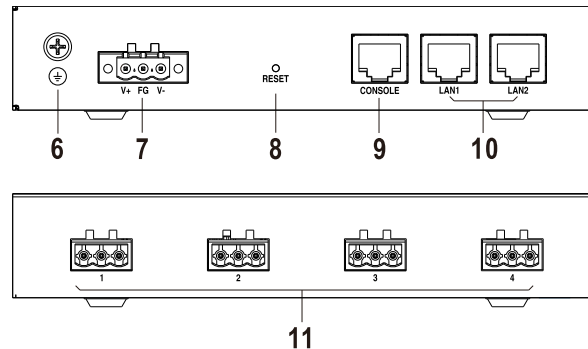

1. Power supply indicator (PWR)
2. Running indicator (RUN)
3. Ethernet interface connection/activity state indicator (LINK1-LINK2)
4. Serial port data transmission indicator (TX1-TX4)
5. Serial port data receiving indicator (RX1-RX4)
6. Grounding screw
7. Power supply input terminal block
8. RESET button
9. CONSOLE port
10. 10/100Base-T(X) 100M Ethernet port RJ45 (LAN1-LAN2)
11. RS-485 serial port terminal block (1-4)

【Mounting Dimension】

Unit: mm

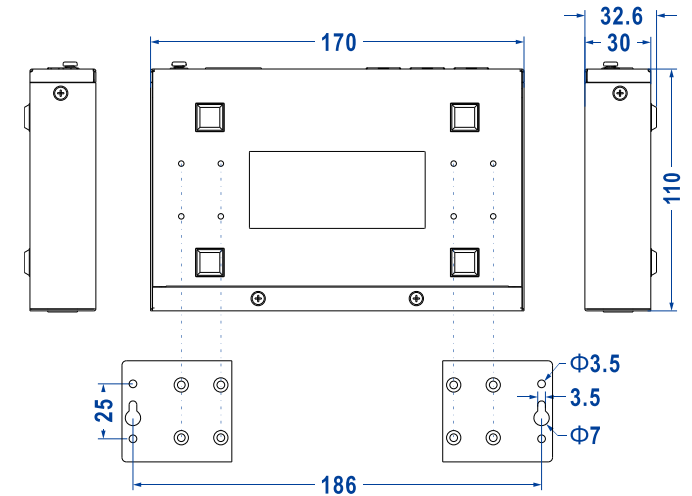

Notice Before Mounting:

- Don't place or install the device in area near water or moist, keep the relative humidity of the device surrounding between 5%~95% without condensation.
- Before power on, first confirm the supported power supply specification to avoid over-voltage damaging the device.
- The device surface temperature is high after running; please don't directly contact to avoid scalding.

【Wall-mounted Device Mounting】

Step 1 Adopt M3 screw to install the left/right mounting board on the device backboard.

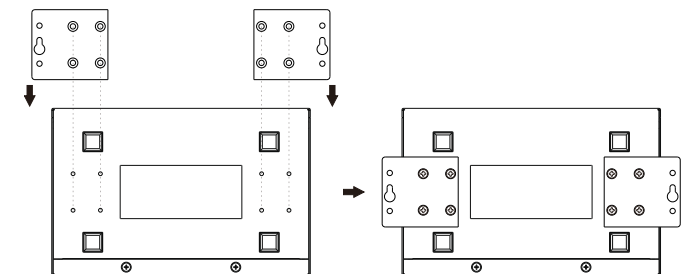

Step 2 On the wall of device mounting, place the device on

the wall for reference or refer to the mounting dimension to mark two screw positions.

Step 3 Nail M4 screws on the wall and keep 2mm interspace reserved.

Step 4 Hang the device on two screws and slide downward, then tighten the screw to enhance stability, mounting ends.

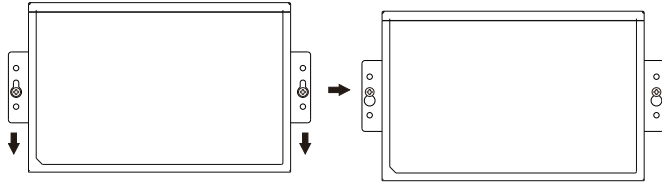

【Wall-mounted Device Disassembling】

Step 1 Device power off.

Step 2 Unscrew the screw on the wall about 2mm.

Step 3 Lift the device upward slightly; take out the device, disassembling ends.



Notice before power on:

- Power ON operation: First insert the power supply terminal block into the device power supply interface, and then plug the power supply plug contact and power on.
- Power OFF operation: first unpin the power plug, then remove the power line, please note the operation order above.

【Power Supply Connection】

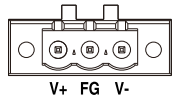

This device supports 1 DC power input terminal, and provides 3-Pin 5.08mm pitch terminal blocks, in which V+ and V- are DC power input, FG is the power grounding input; The power supply supports non-polarity, power supply range: 12 ~ 48VDC.

【Reset Button Setting】

This device provides 1 reset button, press the button for 4-5S then release it to restore factory defaults.

【Serial Port Connection】

➤ RS-485 serial port

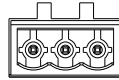

1 2 3

The device provides 4 RS-485 serial ports which adopts 3-pin 5.08mm pitch terminal blocks. Each serial port is equipped with separate isolation component and provides separate GND signal, the isolation voltage is 3kVDC. The pin definitions of serial port as follows:

Pin No.	1	2	3
Definition	D+	D-	GND

【Console Port Connection】



The device provides 1 program debugging port based on RS-232 serial port which can conduct device CLI command management after connecting to PC. The interface adopts RJ45 port, the RJ45 pin definition as follows:

Pin No.	2	3	5
Definition	TXD	RXD	GND

【Checking LED Indicator】

The device provides LED indicators to monitor its operating status, which has simplified the overall troubleshooting process. The function of each LED is described in the table below:

LED	Indicate	Description
PWR	ON	PWR is connected and running normally
	OFF	PWR is disconnected or running abnormally
RUN	Blinking	The system is running normally
	OFF	The system is not running or running abnormally
	ON	System is running abnormally
LINK(1-2)	ON	The Ethernet interface has established a valid network connection.
	Blinking	Ethernet port is in an active

LED	Indicate	Description
		network status
	OFF	Ethernet port has not established valid network connection
TX(1-4)	OFF	The serial port is not transmitting data or transmitting data abnormally
	Blinking	The serial port is transmitting data.
RX(1-4)	OFF	The serial port is not receiving data or receiving data abnormally
	Blinking	The serial port is receiving data

【Logging in to WEB Interface】

This device supports WEB management and configuration. Computer can access the device LAN1 via Ethernet interface. The way of logging in to device's configuration interface via IE browser is shown as below:

Step 1 Configure the IP addresses of computer and the device to the same network segment, and the network between them can be mutually accessed

Step 2 Enter device's IP address in the address bar of the computer browser.

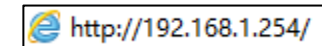

Step 3 Enter device's user name and password in the login window as shown below.

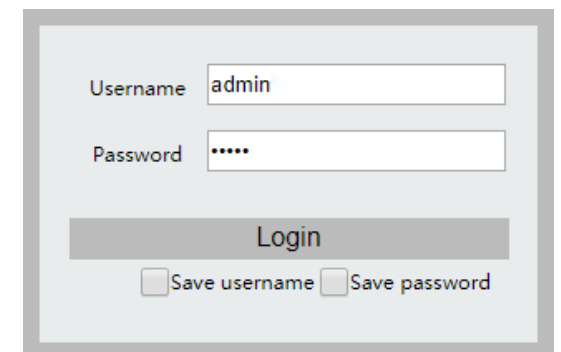

Step 4 Click "Login" button to login to the WEB interface of

the device.



Note:

- The device operates in dual IP mode by default, the default IP address of LAN1 is “192.168.1.254”, the default IP address of LAN2 is “192.168.8.254”.
- The default user name and password of the device are “admin”.
- If the user name or password is lost, user can restore it to factory settings via restore button or management software; all modified configurations will be cleared after restoring to factory settings, so please backup configuration file in advance.
- Please refer to user manual for specific configuration method of logging in to WEB interface and other configurations about network management function.

Full-load	1.9W@12VDC (high temperature)
Working Environment	
Working temperature	-40~75°C
Storage temperature	-40~85°C
Working humidity	5%~95%(no condensation)
Protection grade	IP40 (metal shell)

【Specification】

Panel	
100M copper port	10/100Base-T(X) self-adapting RJ45 port
Serial port	RS-485 serial port, single port with isolation, 3-pin 5.08mm pitch terminal blocks
Console port	CLI command management port (RS-232), RJ45
Indicator	Power indicator, Running indicator, Ethernet port connection/activity state indicator, Serial port data transmission and receiving indicator
Power Supply	
Input power supply	12~48VDC, supports non-polarity
Access terminal block	3-pin 5.08mm pitch terminal blocks
Power Consumption	
No-load	1.7W@12VDC