

X5 System

User Manual



Copyright © ON3 s.r.l. – Bari, Italy
Subject to change without notice

The information contained in this document is provided for informational purposes only. While efforts were made to verify the accuracy of the information contained in this documentation, it is provided “as is” without warranty of any kind.

Third-party brands and names are the property of their respective owners.
www.exorint.com/

Software available in these products is based on OpenSource. Visit oss.exorint.net for more details.

Table of Contents

Introduction	5
Safety notices	5
Safety guidelines	6
1 Overview	8
2 Safety Link	9
2.1 Network configuration	9
2.2 Network SSID	9
2.3 Pairing and Unpairing Procedure with PairingAPP	10
2.3.1 Pairing Lamp	11
2.3.2 Auxiliary Unpairing Input	11
2.3.3 Add a new Base Station	12
2.3.4 Wi-Fi Connection	12
2.3.5 Pairing procedure	12
2.3.6 Unpairing - Delete Base Station	13
2.3.7 Unpairing procedure	13
3 Safety Controls	14
3.1 Emergency Stop Button	14
3.2 Enabling Button	15
3.3 Selector	18
3.4 Safety State Diagram	19
3.4.1 Wireless Handheld	20
3.4.2 Base Station	20
3.5 Safety Outputs	21
3.6 Safety reaction time	22
4 Safety specifications	23
4.1 Safety parameters	23
4.1.1 General Safety parameters	23
4.1.2 Safety functions parameters	23
4.2 Proof test frequency	24
4.3 Lifetime	24
5 Wireless Handheld	25
5.1 Overview	25
5.2 Technical data	27
5.3 Handheld device chemical resistance	28
5.3.1 Test results	29
5.4 Status Indicators	31
5.5 ON/OFF keys	31
5.6 Input Devices	32
5.6.1 Potentiometers	32

5.6.2 Handwheel	32
5.6.3 Keypad	32
5.7 Battery	33
5.7.1 Battery Disposal	33
5.8 Mechanical dimensions	34
5.9 Maintenance	34
5.10 Product Identification	34
6 Base Station	35
6.1 Overview	35
6.2 Technical data	36
6.3 Status Indicators	37
6.4 Power supply	37
6.5 Mechanical dimensions	38
6.6 Product Identification	38
6.7 Maintenance	39
7 Charging Station	40
7.1 Overview	40
7.2 Technical Data	41
7.3 Status Indicators	42
7.4 Mechanical dimensions	43
7.5 Product Identification	44
8 Installation Guidelines	45
8.1 Installation	45
8.2 Configuration and programming	46
8.3 Base Station connectors and cables	47
8.3.1 General Connection Diagram	48
8.3.2 X1 Power Supply	49
8.3.3 X5 Auxiliary I/O	50
8.3.4 X6 Safety Outputs	51
8.3.5 X7 Selector Outputs	52
8.3.6 X8 Serial Port	53
9 Environmentally-friendly disposal	54
10 Standards and Certifications	55
10.1 EC directives	55
10.2 International standards	56
11 Special Instruction for Use	58
12 Unpacking and Packing Instructions	59

Introduction

This document is the Hardware User Manual of X5 System and provides technical information regarding product's functionalities, installation and use of Wireless Handheld and its related Base Station and Charging Station.

This User Manual is intended to give the following information:

CHAPTERS 1 -2 -3

overview to each component, connectivity, pairing and unpairing procedures and safety functions

CHAPTERS 4 - 5 - 6 - 7

general information, detailed technical data, high level explanation of the devices, installation

CHAPTERS 8 - 9 - 10

useful information on safety and certifications

CHAPTER 11 - 12

accessory ordering information

Safety notices

All safety notices in this manual are specified as follows:



INFORMATION

Respecting guidelines and regulations avoids errors



CAUTION!

Respecting guidelines and regulations avoids injuries or damage to material



WARNING!

Respecting guidelines and regulations avoids severe injuries or damage to material



DANGER!

Respecting guidelines and regulations avoids life-risks

Safety guidelines



DANGER!

- The following guidelines shall be strictly complied in order to operate in a safe environment.
- User is responsible for the correct system installation and interfacing to the machine control logic.
- User is responsible for implementing the machine safety related functions.
- User should implement the safety related functions according to the application safety level determined in a previous risk analysis.
- User, during machine control logic implementation, is responsible for considering all conditions related to the machine motion: checking the Emergency Stop Button, Enabling Button and Selector related relays and switches status; checking all possible further Safety Modules available on board of the machine: safety fences, optical barriers and so on.
- User is responsible for considering all further safety and accident prevention guidelines related to the particular working environment in addition and independently to this document.
- User is responsible for observing all safety precautions applying to industrial control systems in accordance with national and international regulations.
- User is responsible for observing that all installation, commissioning and maintenance tasks must be carried out only by qualified personnel, so by persons who are familiar with transport, mounting, installation, commissioning and operation of the product and who have the appropriate qualifications. Furthermore is suggested to follow all national accident prevention guidelines.
- All safety guidelines, cabling schemes, mechanical and electrical limit values listed in the technical data must be read before installation and commissioning and strictly respected.
- User shall be aware which machinery or group of machinery is controlling.
- User shall be aware if the Wireless Handheld terminal is enabled and connected to the machinery that is supposed to control.
- User is not allowed to take care of the maintenance and repair of the X5 System Modules. Each maintenance and repair operation must be remanded to ON3 srl

**INFORMATION**

- All the instructions contained in this manual ensuring user safety must be taken in consideration. Each non-conformity could cause the safety functions integrated in the Wireless Handheld terminal not to work properly.
- Wireless Handheld and Base Station have been designed, developed, and manufactured for conventional use in industry. They were not designed, developed, and manufactured for any use involving serious risks or hazards that could lead to death, injury, serious physical damage, or loss of any kind without the implementation of exceptionally stringent safety precautions. Such risks and hazards include the use of X5 System in the following applications:
 - nuclear reactions monitoring in nuclear power plants;
 - flight control systems;
 - flight safety;
 - mass transit control systems;
 - medical life support systems;
 - control of weapon systems.
- Electrical components that are vulnerable to electrostatic discharge (ESD) must be handled accordingly

**DANGER!**

- Do not touch the connector contacts; do not touch the contact tips when removing the protection covers.
- All kind of environmental (temperature, aggressive atmospheres, humidity) and mechanical stresses over the accepted limits explained in this User Manual must be avoided during transport and storage of the devices.
- Two main considerations must be done in order to prevent damages during transport:
 - always use the original packaging;
 - always keep the right environmental conditions as explained in the technical data.
- Installation must take place according to the documentation and using suitable equipment and tools.

**WARNING!**

- It is important that the Indicators shall be clearly visible and the operator instructed that he can rely on the Emergency Stop Button only when the Indicator is steady ON.
- If the application software allows controlling more than one machinery at the time, then the safety circuits on the plant should be wired in such a way that the Emergency Stop Button will halt all the machinery that could be involved.

1 Overview

The X5 System consists of three devices: Wireless Handheld, Base Station and Charging Station battery charger.

The Wireless Handheld provides all the features of an advanced HMI panel and the potential of an on-board controller that can interface with the most modern PLCs, all within a compact, lightweight and ergonomic design. Wireless connection with certification for Safety Controls makes this product the ideal solution for industrial applications. Integrated devices (Keypad, Potentiometers, Handwheel) can be fully programmed assuring a quick use with your automation project. Wireless Handheld is fully programmable with JMobile.

The safety Wireless link between the Wireless Handheld and the Base Station can be activated/deactivated dynamically through a dedicated pairing procedure. The activation status of the safety link is indicated on Wireless Handheld by the illuminated emergency button and by a status LED, on Base Station by a light device installed on board the machine and by a status LED.

All configuration and control commands selected through the Keypad or the Touchscreen Display, the Handwheel and the Potentiometers status, the Emergency Stop Button, Enabling Button and Selector status are sent by the Wireless Handheld to the Base Station.



Wireless Handheld



Wireless Link



Base Station

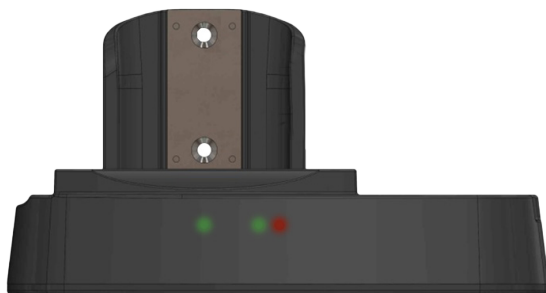

Charging Station

2 Safety Link

Safety Link is a Wi-Fi point-to-point connection between a Wireless Handheld and a Base Station. The same Wi-Fi link is used to exchange Safety and Application data.

2.1 Network configuration

The Wi-Fi link is based on a Private Network where only two devices can be connected at a time: Base Station and Wireless Handheld.

Network Configuration	
Band	2.4GHz / 5GHz, user configurable
Channel	Manual selection
SSID	Fixed
Password	Yes, user configurable

For all details regarding how to setup Network Configuration refer to JMobile Studio User Manual.

2.2 Network SSID

The Network SSID is fixed and based on Base Station Unique Identification (SAFETY UID), hardcoded in the device. User can get Base Station SAFETY UID using System Settings (refer to JMobile Studio User Manual for details) or from device label.



2.3 Pairing and Unpairing Procedure with PairingAPP

PairingAPP is a pre-installed application on the Wireless Handheld that allows you to perform the pairing between the device and any Base Station available for operation. The Wi-Fi link between a Wireless Handheld and a Base Station is dynamic; the devices can be connected and disconnected over the time according the Pairing/Unpairing procedure.

The PairingAPP is opened at every power-up of the Wireless Handheld, but it can be resumed in any moment by pressing K1 and K4 keys simultaneously.

The Pairing Application let user to :

- Manage a list of Base Station devices
- Verify the Wi-Fi signal and battery levels
- Manage Pairing and Unpairing Procedure with a single Base Station



CAUTION!

- The pairing procedure wants to assure the user is aware about the Base Station he wants to establish a safety connection. For this reason it is required for user to look at the Base Station (e.g the pairing lamp), answer correctly to the questions, complete the procedure in a definite time (30 sec every step).
- The pairing procedure is guided by the application but requires the intervention of the operator to identify the Base Station and the confirmation on display of the required information. It is the operator's responsibility to complete each step of the procedure within the timeframe provided (30sec each step).

2.3.1 Pairing Lamp

The functions of the pairing lamp are:

- Support to the pairing procedure for the identification of the Base Station
- Verification of the pairing status of the Base Station

Pairing Lamp Status	Description
ON	PAIRED
OFF	UNPAIRED
BLINK	LINK LOSS

In addition to the pairing lamp, the status of the security Safety Link is indicated by a local LED of the Base Station. The positioning of the pairing lamp must ensure an easy association between the lamp and the machine, as well as facilitate its display at a distance for the implementation of the pairing procedure.



CAUTION!

- If a Base Station, paired with a Wireless Handheld, is subjected to a power cycle, the link status is not restored automatically, but the event is reported by the flashing status of the pairing lamp.

2.3.2 Auxiliary Unpairing Input

The auxiliary unpairing input can be used as an alternative recovery procedure to reset the state of Base Station to IDLE when the device is in SAFE State.

2.3.3 Add a new Base Station

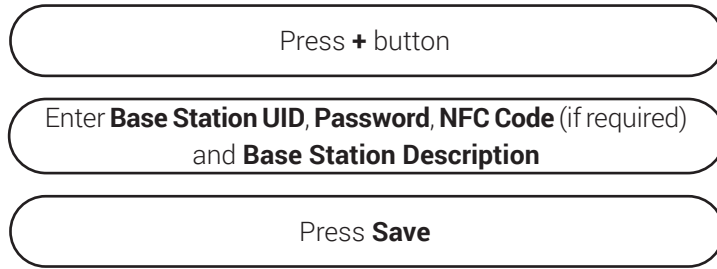

2.3.4 Wi-Fi Connection

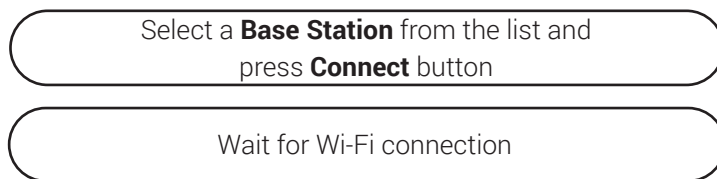

CAUTION!

- It is recommended to select “Connect automatically” checkbox if user wants to use the Wireless Handheld with the same Base Station. This option speeds up the Wi-Fi link setup.

2.3.5 Pairing procedure

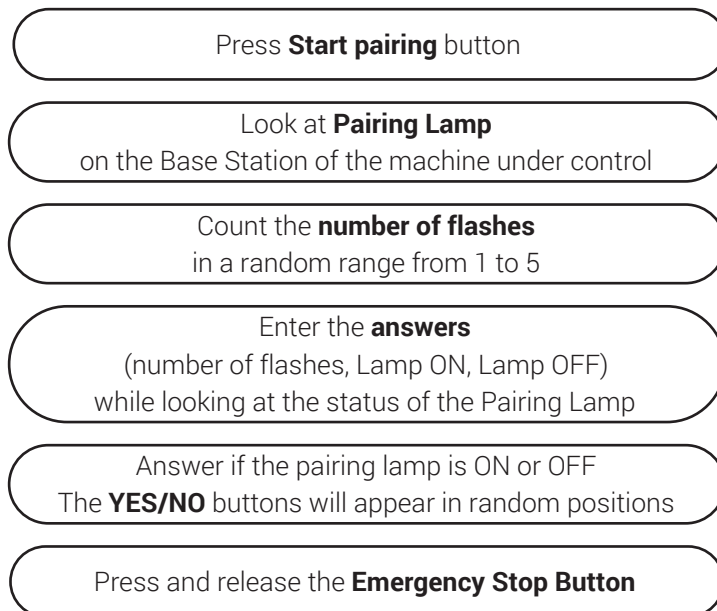

The pairing procedure can fail for the following reasons:

- Required by user with "Abort" button
- Wrong answers
- Timeout (User not entering response within the predefined time) 30 seconds

In case of failure the procedure must be repeated.

2.3.6 Unpairing - Delete Base Station

Select a **Base Station** from the list and
press - button

2.3.7 Unpairing procedure

Press K1 and K4 keys simultaneously then press the **Unpair**
button and confirm the operation by pressing the **Yes** button

3 Safety Controls

The Wireless Handheld and the Base Station are designed to provide Safety Controls that are enabled only when the two devices are paired to each other over a safety link.

The Safety Controls are: Emergency Stop Button, Enabling Button and Selector.

When the Wireless Handheld and the Base Station are paired, the state of Safety Controls are replicated on the Base Station as Safety Outputs.

3.1 Emergency Stop Button

The Emergency Stop Button provides two redundant switching contacts. The two safety relays that replicate their status on the Base Station have two contacts per each and follow the behavior shown in the table below. User should directly connect the relays Outputs to the machine cabinet and monitoring devices. The Stop function provided by Wireless Handheld and Base Station allows the user to fulfil high PL (according to EN ISO 13849-1:2008) and SIL (according to EN 62061:2005) for the safety function once it is interfaced with the machine control logic.

- The Emergency Stop Button is a Safety Control with internal illumination.
- It becomes illuminated only when the Safety link Wireless Handheld/Base Station is active.
- The device is associated to two relay contacts present on the Base Station and it behaves as reported

Emergency Stop Button	Relay Contacts (Base Station)
PULL	Closed
PUSH	Open



CAUTION!

- User is responsible for interfacing the system to the machine control logic and implementing the Stop function according to the safety level determined in a previous risk analysis.
- The Emergency Stop Button cannot be marked or labelled as “Emergency Stop Button” even if user can implement the Stop function in stop category 0 or 1 of EN 60204-1:2006.
- The Emergency Stop Button must not to be used to enable power line of the machinery.
- In case of drop or other possible damages of the device, the stop function operation must always be checked by the operator.
- Releasing the Emergency Stop Button must never cause an uncontrolled restart. User is responsible for implementing these controls on the machine control logic.
- The Emergency Stop Button on the Wireless Handheld is not a substitute for the permanently-wired Emergency Stop Button located on the machine.
- The Emergency Stop Button on the Wireless Handheld terminal is disabled if terminal is shut OFF, unpaired from the related Base Station or if Base Station is shut OFF.
- User can always access through the HMI to all diagnostics information about the safety module built up by the Wireless Handheld and Base Station. User must always refer to ON3 S.r.l. for maintenance and repair operations.



INFORMATION

- The Emergency Stop Button and its related relays are Safety Modules, subject to internal functional tests. In case of hardware failure the Safety State Diagram enters Emergency state.

3.2 Enabling Button

The Enabling Button is a three-position switch providing two redundant switching contacts. User should directly connect the relays Outputs to the machine cabinet and monitoring devices. Respecting the standard EN60204-1, two positions, Null and Panic, represent off condition while only the Enable position allows activation. The enabling function provided by Wireless Handheld and Base Station allows the user to fulfil high PL (according to EN ISO 13849-1:2008) and SIL (according to EN 62061:2005) for the safety function once it is interfaced with the machine control logic.

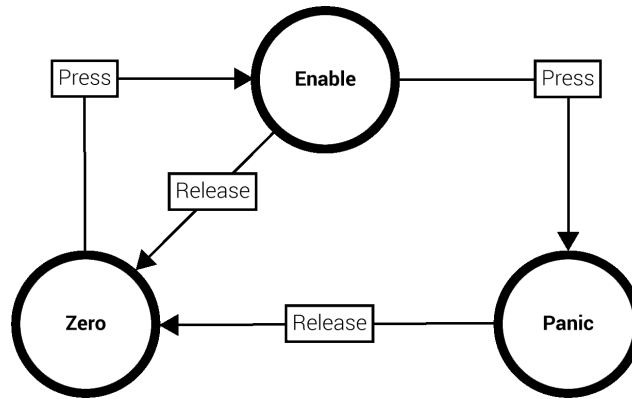

The control is associated to two relay contacts present on the Base Station and it behaves as reported:

Enabling Button (Wireless Handheld)	Relay Contacts (Base Station)
Zero	Open
Enable	Closed
Panic	Open

Zero position

When not pressed the Enabling Button returns to the zero position

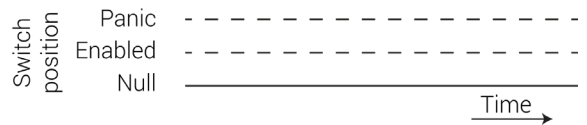

Enable position

When pressed the Enabling Button goes into the enabling position. This condition is often associated to machine movement activation. When released it goes back to the null position

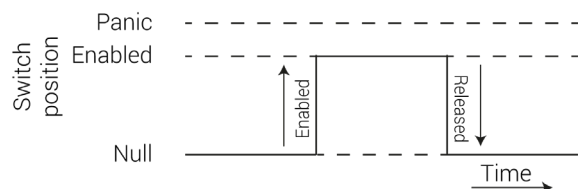

Panic position

When the enabling device is pushed all the way in it goes to the panic position which corresponds to the same contact condition as the zero state.

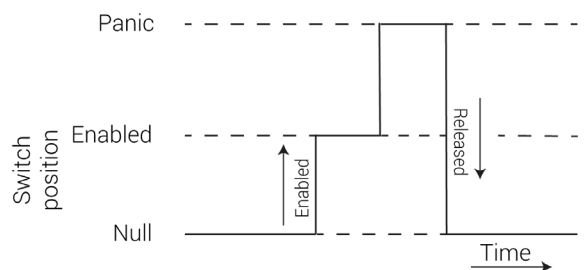

If the switch is pushed all the way in and then released it goes directly to the Null state skipping the Enable position.

**CAUTION!**

- User is responsible for interfacing the system to the machine control logic and implementing the Enabling function according to the safety level determined in a previous risk analysis.
- The enable switch fulfils its protective function only if the operator can recognize the danger in time.
- The Enabling Button and its related relays are Safety Modules, subjected to internal functional tests. In case of hardware failure the Safety FSM enters Emergency state.
- In case of dangerous states the logic controller, another conscious start command should be required to allow activation additionally to the enable switch.
- The only person permitted in the dangerous area is the person activating the enable switch.
- User can always access through the HMI to all diagnostics information about the safety module built up by the Wireless Handheld and Base Station. In case of faults or failures user must always refer to ON3 S.r.l for maintenance and repair operations.

**INFORMATION**

- The enabling function is implemented with:
 - the Enabling Button;
 - the logic circuits on the Wireless Handheld that monitor the Enabling Button status and transmit it to the Base Station;
 - the logic circuits on the Base Station that receive the Enabling Button status and replicate it on the safety relays.

3.3 Selector

This is a 16 positions rotary switch with binary Outputs.

When the Wireless Handheld device is paired to a Base Station, the status of the Selector is replicated to the Base Station as Safety Outputs (24Vdc High Side driver).



CAUTION!

- User is responsible for interfacing the system to the machine control logic and implementing the State Selecting function according to the safety level determined in a previous risk analysis.
- The Selector function should be only related to the selection of the various working modes available on the machine by the logic controller.
- The Selector and its related Outputs are Safety Modules, subjected to internal functional tests. In case of hardware failure the Safety State Diagram Emergency state.
- User can always access through the HMI to all diagnostics information about the safety module built up by the Wireless Handheld and Base Station. In case of faults or failures user must always refer to ON3 S.r.l. for maintenance and repair operations.
- In order to avoid false fault detection the User must provide power supply to Selector Safety Output even if they are not used.

3.4 Safety State Diagram

This paragraph provides a description of Safety State Machine for the X5 System, including one Wireless Handheld and one Base Station. For both devices the States are:

Legend	
OFF	The device is switched OFF
IDLE	The device is switched ON, the status is UNPAIRED
RUN	The device is switched ON, the status is PAIRED
SAFE	The device is switched ON, the status is UNPAIRED
SAFE - P	The device is switched ON, the status is PAIRED
EMG	The device is switched ON, the status is PAIRED

The transition among Safety States are defined by the following Events:

Legend	
OFF	Switch OFF
ON	Switch ON
PAIR	Pairing procedure (Wireless Handheld)
UNPAIR	Unpairing procedure (Wireless Handheld)
AUX-REC	Auxiliary unpairing Input (Base Station)
LINK-LOSS	Loss of Wi-Fi Link
LINK-REC	Recovery of Wi-Fi Link
PAIR-LOSS*	Loss of PAIRED Status
FAIL	System Failure

*Note: PAIR-LOSS can be caused by a device fault or hardware reset when the device is in RUN or SAFE-P States

3.4.1 Wireless Handheld

Safety FSM	Event							
	OFF	ON	PAIR	UNPAIR	LINK-LOSS	LINK-REC	PAIR-LOSS	FAIL
OFF	-	IDLE	-	-	-	-	-	-
IDLE	OFF	-	RUN	-	-	-	-	EMG
RUN	OFF	-	-	IDLE	SAFE - P	-	SAFE	EMG
SAFE	OFF	-	-	IDLE	-	-	-	EMG
SAFE - P	OFF	-	-	IDLE	-	RUN	SAFE	EMG
EMG	OFF	-	-	-	-	-	-	-

3.4.2 Base Station

Safety FSM	Event								
	OFF	ON	PAIR	UNPAIR	AUX-REC	LINK-LOSS	LINK-REC	PAIR-LOSS	FAIL
OFF	-	IDLE SAFE*	-	-	-	-	-	-	-
IDLE	OFF	-	RUN	-	-	-	-	-	EMG
RUN	OFF	-	-	IDLE	-	SAFE - P	-	SAFE	EMG
SAFE	OFF	-	RUN	-	IDLE	-	-	-	EMG
SAFE - P	OFF	-	-	-	IDLE	-	RUN	SAFE	EMG
EMG	OFF	-	-	-	-	-	-	-	-

* When powered up, the device enters Safe State if previously switched off in Safe State

3.5 Safety Outputs

Based on the X5 System (Wireless Handheld, Base Station) Safety FSM, the status of Safety Outputs controls are the following:

Legend	
ESi	Actual EMERGENCY STOP input (Wireless Handheld)
ESo	Actual EMERGENCY STOP output (Base Station)
EDi	Actual 222 DEVICE input (Wireless Handheld)
EDo	Actual ENABLING DEVICE output (Base Station)
SSi	Actual STATE SELECTOR input (Wireless Handheld)
SSo	Actual STATE SELECTOR output (Base Station)
(SS)	Last STATE SELECTOR output (Base Station)
O	Open
C	Closed
Z	High Impedance

Base Station State	Wireless Handheld State					
	OFF	IDLE	RUN	SAFE	SAFE - P	EMERGENCY
OFF	ESo=0 EDo=0 SSo=Z	ESo=0 EDo=0 SSo=Z	-	ESo=0 EDo=0 SSo=Z	-	ESo=0 EDo=0 SSo=Z
IDLE	ESo=C EDo=0 SSo=(SS)	ESo=C EDo=0 SSo=(SS)	-	ESo=C EDo=0 SSo=(SS)	-	ESo=C EDo=0 SSo=(SS)
RUN	-	-	ESo=ESi EDo=EDi SSo=SSi	-	-	-
SAFE	ESo=0 EDo=0 SSo=(SS)	ESo=0 EDo=0 SSo=(SS)	-	ESo=0 EDo=0 SSo=(SS)	-	ESo=0 EDo=0 SSo=(SS)
SAFE - P	-	-	-	-	ESo=0 EDo=0 SSo=(SS)	-
EMERGENCY	ESo=0 EDo=0 SSo=Z	ESo=0 EDo=0 SSo=Z	-	ESo=0 EDo=0 SSo=Z	-	ESo=0 EDo=0 SSo=Z



INFORMATION

- When the System enters SAFE State because a Wireless Handheld/Base Station power-off condition, a new Pairing procedure is required to enter RUN state.
- When the System enters SAFE State because Safety Link loss, the System enters automatically RUN state as soon as the link is resumed.

3.6 Safety reaction time

The table provides reaction timing for the Safety Outputs caused by any changing of the status of the Safety Controls.

Safety Outputs	Condition	Typ [ms]	Max [ms]
Emergency STOP	Closed-to-Open	75	350
	Open-to-Closed	125	
Enabling	Closed-to-Open	75	350
	Open-to-Closed	125	
Selector	All Directions	75	350

4 Safety specifications

4.1 Safety parameters

4.1.1 General Safety parameters

The following general parameters have been considered for the PFHd evaluation:

Part	Mean number of annual operations	Working days per year	Working hours per day	Working hours per year	Resulting cycle period
Emergency Stop Push Button	48,000 cycles / year	240	16	3840	1.152s = 19.2min
Enabling Device Push Button	12,000 cycles / year	240	16	3840	288s = 4.8min
State Selector switch	1,920 cycles / year	240	16	3840	7200s = 120min



DANGER!

- The number of mean annual operations indicated in the previous table cannot be exceeded because the declared PFHD is guaranteed only if this number is respected.

4.1.2 Safety functions parameters

The following parameters apply:

Safety function	Safety function mode	SIL (IEC 61508)	PFHd (IEC 61508)	Performance level (EN 13849-1)
Safe Stop	High demand or continuous mode	SIL3	$6 \cdot 10^{-8}$ 1/h	PLd, Cat.3
Enabling Device Push Button	High demand or continuous mode	SIL3	$6 \cdot 10^{-8}$ 1/h	PLd, Cat.3
Selector switch	High demand or continuous mode	SIL1	$1.5 \cdot 10^{-6}$ 1/h	PL=b, Cat.B

Maximum reaction time for all three safety functions is 350ms. Reaction time is measured between the following events:

- ES and ED functions => from push button change of state to new stable relay contact state
- SS function => from state selector switch change of state to new stable output driver state

4.2 Proof test frequency

The proof test must be executed at least one time every 8760 hours. This applies separately to the terminal and to the Base Station (i.e. both the terminal and the Base Station must be tested at least one time every 8760 hours). It includes three parts and can be executed directly on the machine where the system is installed.



DANGER!

- Since the probability that the safety functions will fail during the proof test is not 0, this test shall be executed in a controlled situation (e.g.: when the Enabling Device is tested, the operator must be outside the operating range of a moving machine).

Part 1: proof test of the Safe Stop function

The Emergency Stop push button must be pressed and the operator must verify that the machine is stopped in this condition. Then the Emergency Stop push button must be released and the operator must verify that the machine remains stopped until the standard “Reset – Start” sequence is executed on its console.

Part 2: proof test of the Safe Enable function

The Enabling Device push button must be set in central position starting from the released position. The operator must verify that the machine is enabled in this condition. Then the Enabling Device push button must be fully pressed and the operator must verify that the machine is disabled in this condition. At this point the Enabling Device push button must be set back to the central position and the operator must verify that the machine remains disabled in this condition. Finally, the Enabling Device push button must be fully released and the operator must verify that the machine remains disabled in this condition.

Part 3: proof test of the Safe Selector function

The Selector switch must be set in all 16 positions and the operator must verify that the machine operating mode is set in the relevant state.

4.3 Lifetime

Lifetime is 87600 hours (i.e.: 10 years approximately).

5 Wireless Handheld

5.1 Overview

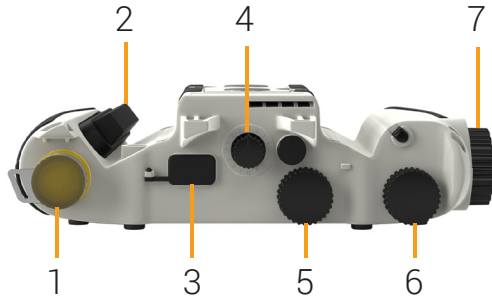

TOP

- 1 Emergency Stop Button
- 2 Enabling Button
- 3 USB
- 4 Selector
- 5 Potentiometer 2
- 6 Potentiometer 1
- 7 Handwheel

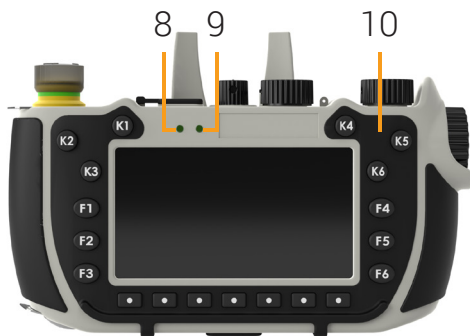

FRONT

- 8 Status LED 1
- 9 Status LED 2
- 10 Keypad

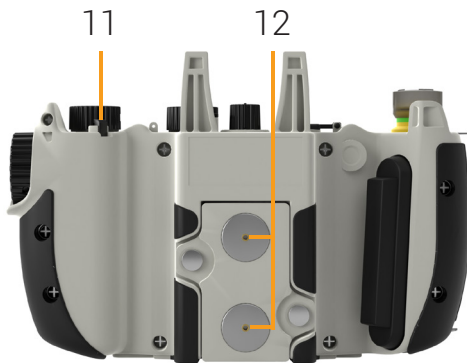

BACK

- 11 Touchscreen pen
- 12 Hanging magnets

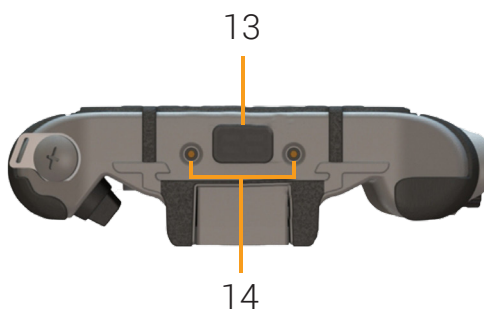

BOTTOM

- 13 USB
- 14 Battery charging contact

The Wireless Handheld is an advanced HMI device characterized by:

- Functional hand grip, user configurable
- Touchscreen display interface with stylus pen
- Keyboard with 19 Keys
- 2 potentiometers and a wheel
- 2 USB Host Ports
- NFC reader
- 2 status indicators
- Safety devices (Emergency Stop Button, Enabling Device and Selector)
- Comfortable and safe access to safety devices
- Comfortable and secure handling using rubber membrane Keypad and covering surface
- Rubber covered keys with mechanical pressure point
- Comfortable handling, also using gloves, thanks to well-designed command key spacing
- Clear display, user configurable brightness
- Vibration and shock resistant according to EN 61131-2:2007, EN 61131-2 cl. 6.3.1, EN 60068-2-6, EN61131-2 cl. 6.3.2, EN 60068-2-27
- Non-flammable material (fulfils UL 94-5VA) housing, impact-resistant, water-resistant IP 64, cleaning agents (alcohol and fabric conditioner), oils, cutting oils (drilling oils), fat and lubricants resistant
- Extremely robust housing. Drop-tested according to EN 61131-2:2007 random drops 1mt

The device is equipped with dual band Wi-Fi interface 2.4/5GHz, compatible IEEE 802.11a/b/g/n.

5.2 Technical data

System Resources	
Display - Colours	5" TFT LED - 64K colours
Resolution	480x272
Brightness	300 Cd/m ² typ.
Dimming	Yes
Touchscreen	Resistive
CPU	i.MX6UL ARM Cortex A7 - 528 MHz
Operating System	Linux 4.14
Flash	4 GB
RAM	512 MB
Real Time Clock, RTC Back-up	Yes, rechargeable Lithium battery (not user-replaceable)
Handwheel	Yes
Potentiometer	2
Selector	16 positions Rotary Switch
Emergency Stop Button	Yes, illuminated
Enabling Button	3 positions
Status Indicators	2 bi-colour LED
Keys	19 user-programmable
Sensors	3-axis Accelerometer, Temperature (internal)
Buzzer, Vibrator	Yes
Interface	
Wireless	IEEE Std 802.11a/b/g/n
USB	2 Host V2.0, 250mA max
NFC	Yes
Ratings	
Power Supply	Rechargeable Battery BATT3V74A401
Battery capacity	4400 mAh (6h of autonomy typ.)
Charging Station	Yes
Environment Conditions	
Operating Temperature	+5 to +45°C
Storage Temperature	-20 to +70°C
Operating / Storage Humidity	5-85% RH, non condensing
Protection Class	IP64 (not UL evaluated)
Dimensions and Weights	
Faceplate LxH	220x144 mm
Depth D+T	63 mm
Weight	Approx 0.8 Kg

5.3 Handheld device chemical resistance

Test 1 (Less strict)

The units under test (UUT) are placed in a closable plastic box (120 x 85 x 65 mm).

A ball of absorbent cotton appositely tintured with solvent will be placed above the UUT; to avoid early evaporation, a generic solid body will be put over the ball or, in a more simply way, the closable plastic box will be closed. After a 10 minutes wait, the eventually body and the ball of absorbent cotton will be removed; the solvent that remains on the UUT will not be wiped off and the box will be closed immediately afterwards for 24 hours.

The test will be performed at environmental temperature (about 20°C).

Test 2 (Very strict)

The units under test (UUT) are fully and thoroughly wet by solvent, then will be closed into a closable box (120 x 85 x 65 mm) for 24 h. Approximately 5 ml solvent will be sprayed over the UUT. The box will be closed and the UUT will remain in the closed box for at least 24 hours.

The test will be performed at environmental temperature (about 20°C).

Touchscreen test procedure

The Touchscreen is placed into a closable plastic box (120 x 85 x 65 mm) and a ball of a Base Station or bent cotton appositely tintured with solvent will be placed above it, then the box will be closed for 1 h.

The test will be performed at environmental temperature (about 20°C).

5.3.1 Test results

Chemical solvent	Test 1 Passed	Test 2 Passed	Notes
Denatured Ethyl Alcohol	Rubber (Keypad) Handles Terminal housing Rubber cap Rubber (lateral cover)	Rubber (Keypad) Handles Terminal housing Rubber cap Rubber (lateral cover)	
Diesel	Rubber (Keypad) Handles Terminal housing Rubber cap Rubber (lateral cover)	Handles Terminal housing Rubber cap Rubber (lateral cover)	Test 2: Rubber (Keypad): heavy deformation; reduced hardness
Unleaded Gasoline	Rubber (Keypad) Handles Terminal housing Rubber cap Rubber (lateral cover)	Rubber (Keypad) Handles Rubber cap Rubber (lateral cover)	Test 2: Terminal housing: housing gets doughy
Blu Diesel	Rubber (Keypad) Handles Terminal housing Rubber cap Rubber (lateral cover)	Handles Terminal housing Rubber cap Rubber (lateral cover)	Test 2: Rubber (Keypad): rubber gets doughy
Silicone spray	Rubber (Keypad) Handles Terminal housing Rubber cap Rubber (lateral cover)	Rubber (Keypad) Terminal housing Rubber cap Rubber (lateral cover)	Test 2: Handles: loss of colour
Kluber KONSTANT OY 32	Rubber (Keypad) Handles Terminal housing Rubber cap Rubber (lateral cover)	Rubber (Keypad) Handles Terminal housing Rubber cap Rubber (lateral cover)	
Acetone	Rubber (Keypad) Rubber (lateral cover)	Rubber (Keypad) Rubber (lateral cover)	Test 1 and 2: Handles: loss of colour Terminal housing: clouding Rubber cap: swelling
Shell Garia 9603 M15	Rubber (Keypad) Handles Terminal housing Rubber cap Rubber (lateral cover)	Rubber (Keypad) Handles Terminal housing Rubber cap Rubber (lateral cover)	

Touchscreen test results

Test passed with the following solvents:

- Unleaded Gasoline
- Denatured Ethyl Alcohol
- Diesel
- Kluber KONSTANT OY 32
- Acetone

5.4 Status Indicators

There are two bi-colours LED.

LED1:

Colour	Status	Description
RED	OFF	Wireless Handheld not paired / Safety Link Loss
RED	ON	Wireless Handheld paired
GREEN	OFF	Battery charging OFF
GREEN	BLINKING	Battery charging COMPLETED
GREEN	ON	Battery charging ON

LED 2:

Colour	Status	Description
-	-	-
RED	ON	CPU Error
-	-	-
-	-	-
GREEN	ON	CPU Run



CAUTION!

- In case of errors contact supplier.

5.5 ON/OFF keys

To switch on or off the Wireless Handheld press the F2 and F5 keys simultaneously for a few seconds. The boot of the system is indicated by the red and the green indicators switching on in sequence.

Before making the first power is recommended to run a complete cycle of battery charge.

5.6 Input Devices

5.6.1 Potentiometers

Resolution: 0-255 linear

5.6.2 Handwheel

- Counter goes from 0 to 32767.
- Clockwise turns increment while counter-clockwise turns decrement the counter.

5.6.3 Keypad

The mobile panel has a rubber covered membrane keypad with 19 keys, 12 keys are named Function Keys“(F1..6,K1..6), 7 keys are named “dots keys”. All of them are user programmable by software application.

5.7 Battery

The Wireless Handheld is powered by a removable battery attached to the back of the device.

The battery capacity is 4400mAh and provides autonomy for about 6h with 100% charged battery. Time depends on the system load.

The battery can be charged individually or when installed on the Wireless Handheld using the Charging Station that is part of the X5 System. A green status LED on the Wireless Handheld signals when the charging process is in progress. A full charge cycle requires about 3h when the battery is completely discharged.

The battery is fixed on the rear side of the device via two locks.

The procedure for battery replacement is the following:

- Unscrew the locks
- Replace the battery
- Screw the locks

The battery charge status can be checked dynamically in several ways:

- System Settings
- Pairing App
- System variable available from App



WARNING!

- Use only the supplied battery code. The use of alternative solutions could cause malfunctions or damage to the product as well as voiding the warranty and product certifications.
- Do not use the Wireless Handheld with a battery level of less than 5% to avoid the device's sudden shutdown.

5.7.1 Battery Disposal

Dispose of batteries according to local regulations.

5.8 Mechanical dimensions

All dimensions are expressed in mm.

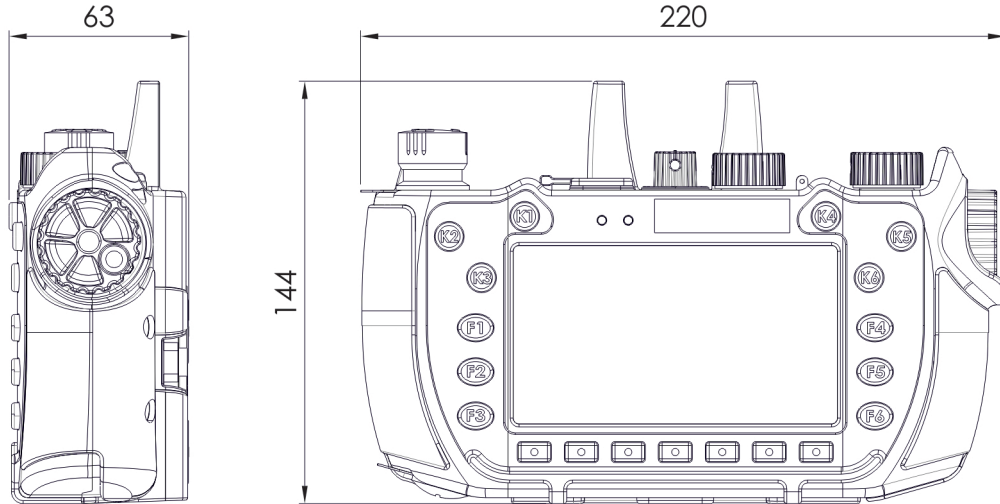







5.9 Maintenance

Verification of safety devices as described in Chapter 4.

5.10 Product Identification

Wireless Handheld is labelled with a sticker nameplate that allows unique identification showing:

Model Name	ONE X5 Wireless
Product Part Number	BY EXOR INTERNATIONAL P.N.: X5SWJ0HYE0
Product Version	V.: xxxxxxxxxxxxxxxx
Product Serial Number	S.N.: AA000 14D3 123456789AA
Production Date (yy/mm)	2111 
Manufacturer Name and Address	  cULus IND. CONT. EQ LISTED 
CE MARK	ON3 s.r.l. Via Monte Fiorino 9 IT-37057 San Giovanni Lupatoto (VR)  

6 Base Station

6.1 Overview

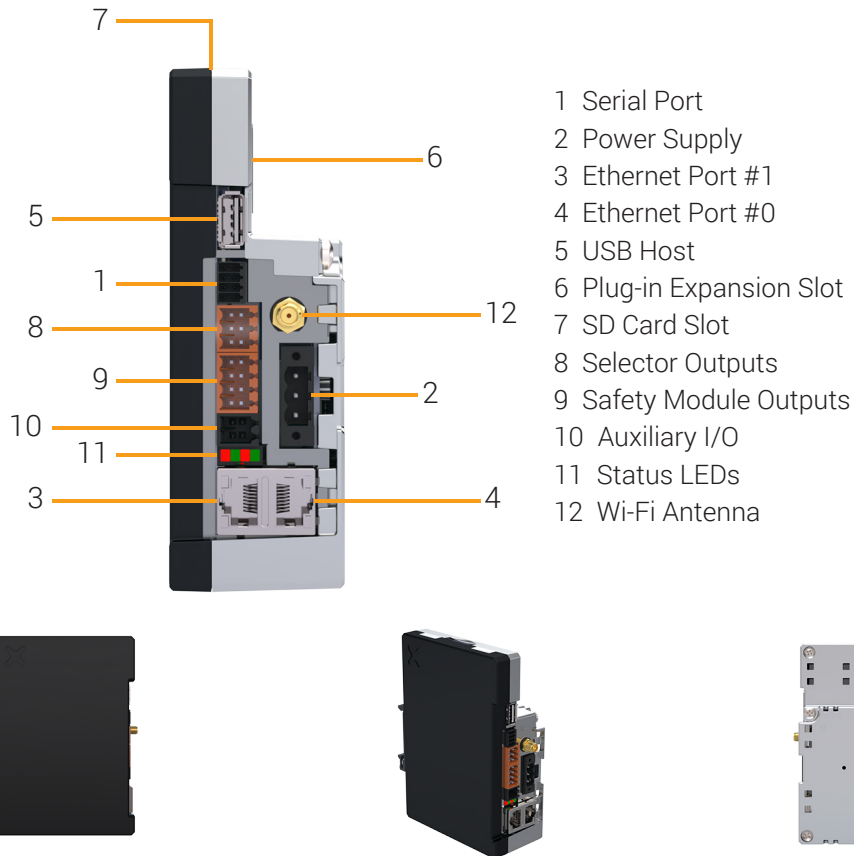

Base Station is a compact controller designed for machine installation with DIN bar. The device is equipped with several communication ports for interfacing with various devices:

- 2 ports Ethernet 10/100 T-base
- 1 programmable Serial Port RS232/485/422
- 1 USB Host 2.0 port
- 1 SD-Card connector
- Support expansion modules (plug-ins)
- Safety Devices (relay outputs for emergency key and enabling device, Outputs for Selector)

The device is equipped with dual band Wi-Fi interface 2.4/5GHz, compatible IEEE 802.11a/b/g/n, on SMA connector for external antenna.

6.2 Technical data

System Resources	
CPU	i.MX6UL ARM Cortex A7 - 528 MHz
Operating System	Linux 4.14
Flash	4 GB
RAM	512 MB
FRAM	32Kbytes
Real Time Clock, RTC Back-up	Yes, rechargeable Lithium battery (not user-replaceable)
Buzzer	Yes
Sensors	Temperature (internal)
Safety Outputs	Emergency Stop (2+2 relay contacts NO) Enabling Device (2+2 relay contacts NO)
Digital I/O	1DI, 2DO Safety Auxiliary functions
Interface	
Wireless	IEEE Std 802.11a/b/g/n (Safety Link)
Ethernet Port	2 (port 0 - 10/100, port 1 - 10/100)
USB Port	1 (Host v. 2.0, max. 500 mA)
Serial Port	1 (RS232/422/485, sw programmable)
SD Card	Yes
Expansion	1 slot for plug-in modules
Ratings	
Power Supply	24 Vdc (10 to 32 Vdc)
Current Consumption	0,4 A max. at 24 Vdc
Input Protection	Electronic
Environment Conditions	
Operating Temperature	+5 to +45°C
Storage Temperature	-20 to +70°C
Operating / Storage Humidity	5-85% RH, non condensing
Protection Class	IP20 (not UL evaluated)
Dimensions and Weights	
Faceplate LxH	45x134 mm
Depth D+T	102 mm
Weight	Approx 0.65 Kg
Installation	DIN Rail (TS35)

6.3 Status Indicators

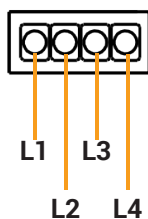

LED	Colour	Description
L1	RED	CPU Error
L2	GREEN	CPU Run
L3	RED	Base Station Paired
L4	GREEN	Power Supply

6.4 Power supply

The device requires a nominal power supply +24Vdc SELV (Class 2 according to UL Standards), with Ground connection (Functional Ground).

6.5 Mechanical dimensions

All dimensions are expressed in mm.

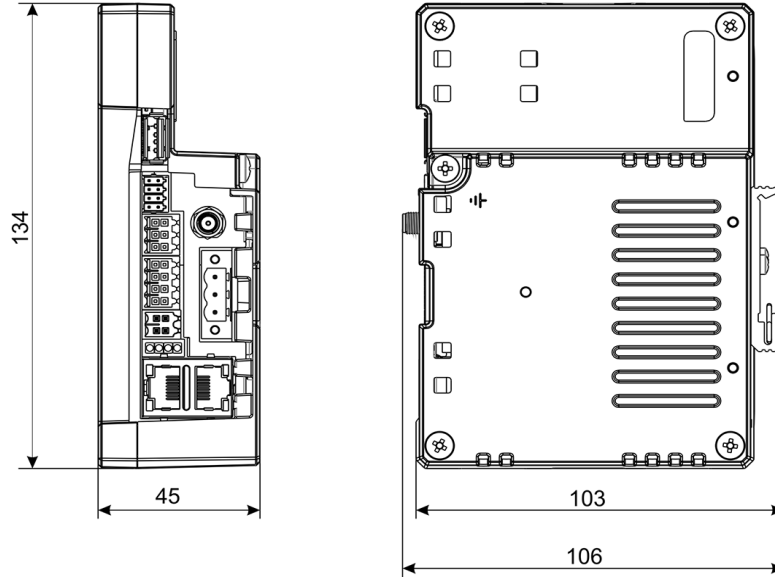

6.6 Product Identification

Base Station is labeled with a sticker nameplate that allows unique identification showing:

Model Name	Xbase
Product Part Number	24V $\overline{=}$ 0.40A
Product Version	P.N.: X5B0J000YE0
Product Serial Number	V.: xxxxxxxxxxxxxxxx
Production Date (yy/mm)	S.N.: AA000 14DF 123456789AA
Manufacturer Name and Address	2111
CE MARK	
	ETH1 IP 192.168.0.1 MASK 255.255.255.0
	ON3 s.r.l. Via Monte Fiorino 9 IT-37057 San Giovanni Lupatoto (VR)
	SAFETY UID: xxxxxxxxxxxxxxxx

6.7 Maintenance

The devices of the X5 System do not require special interventions by the user for the maintenance part except:

- Periodic verification of safety devices

In case of malfunction, X5 System devices must not be opened or repaired by the user, otherwise the warranty will be void and the functional safety certificates will be violated. The failed device shall be returned to the manufacturer using the RMA procedure.

7 Charging Station

7.1 Overview

Charging Station is a docking and battery charging device for the Wireless Handheld device. It can charge at the same time the Wireless Handheld plus one spare battery.

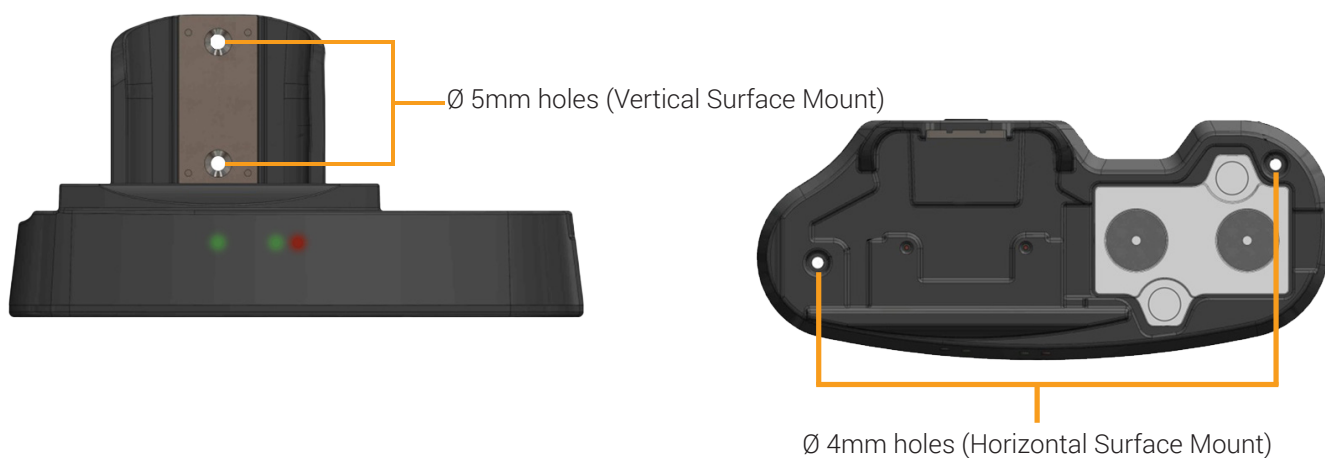

7.2 Technical Data

Ratings	
Power Supply	24V $\overline{\text{---}}$ \pm 25 % Supplied by a SELV (Class 2 according to UL Standards) or PELV Power Supply
Voltage Output	5V \pm 10 %
Power Consumption	0,9 A (max) @ 24V
Protection Type Voltage Input	Protection from polarity inversion, over-voltage and under-voltage
Current Input	Protection from overload current
Voltage Output	Internally regulated
Environment Conditions	
Operating Temp	+5 to +45°C
Storage Temp	-20 to +70°C
Operating / Storage Humidity	5-95% RH, non condensing
Protection Class	IP64 (not UL evaluated)
Flame resistant	Fulfils UL 94V-0: HB 1/16"
Dimensions and Weights	
Faceplate LxH	213x113 mm
Depth D+T	89 mm
Weight	Approx 0.4 Kg

7.3 Status Indicators

The status indicator the charging status:

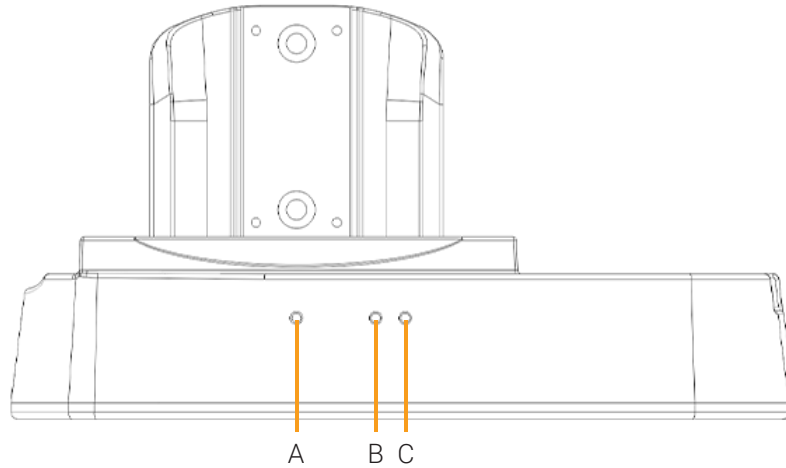

LED	Colour	Description
A	GREEN	Power ON
B*	GREEN	Auxiliary Battery charged
C*	RED	Auxiliary Battery charging

*LED B and C are turned ON alternately

While charging the red LED (LED C) is on; green LED (LED B) off; at the end of charging the green LED (LED B) is on.

Charging Station has a back side supply cable. The skilled installer can disconnect the power cable from the side and connect it to bottom side maintaining the same cap where the cable is already inserted.



CAUTION!

- Disconnection and connection cable must be performed by a skilled installer.
- SELV Extra low voltage Power Supply / Limited power source according to EN 60950-1 and Class 2 according to UL Standards.



INFORMATION

- When not in use, it is always suggested to place the Wireless Handheld device on the Charging Station.
- When the Wireless Handheld is shut off and not recharged, the battery typically discharges in 7 days. In this case you must complete charging cycle before using the Wireless Handheld device.

7.4 Mechanical dimensions

All dimensions are expressed in mm.

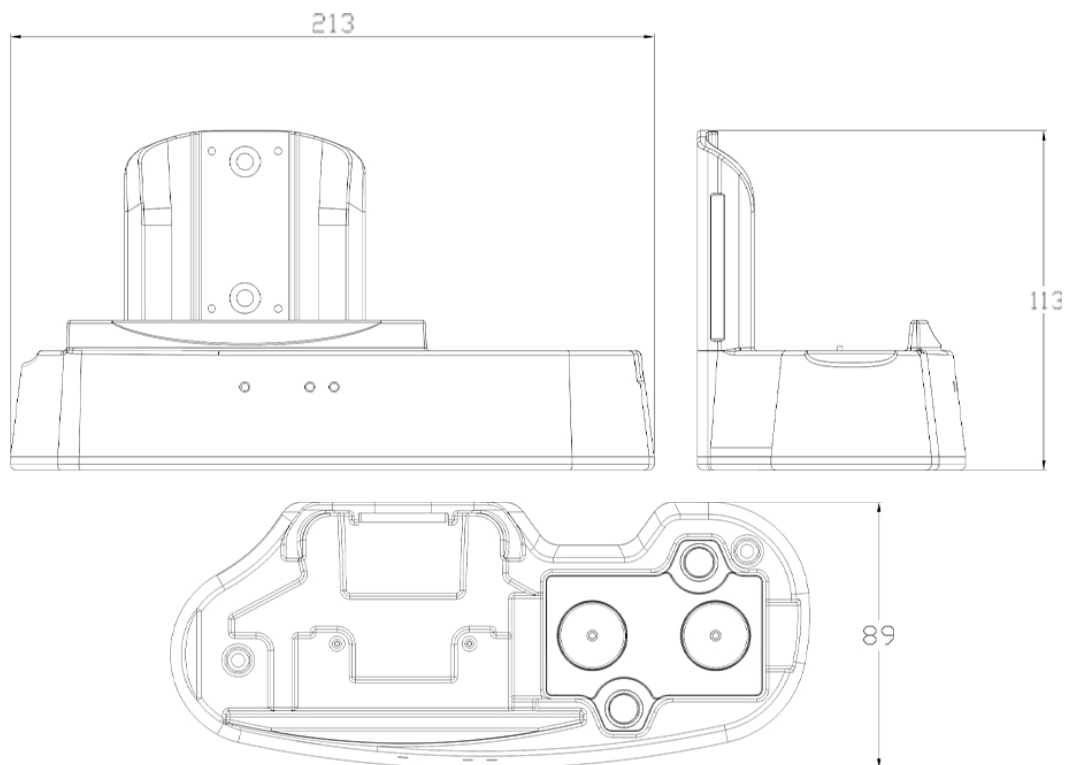

7.5 Product Identification

Charging Station is labeled with a sticker nameplate that allows unique identification showing:

Model Name	
Product Part Number	
Product Version	
Product Serial Number	
Production Date (yy/mm)	
Manufacturer Name and Address	
CE MARK	

8 Installation Guidelines

8.1 Installation

The Base Station is designed for quick installation on DIN rail (IP20 protection, not UL evaluated)

Provide ground connection at dedicated mechanical screw and at power connector pin.

The Wi-Fi antenna supplied is external and connected to the Base Station device on SMA connector. It is recommended to use a Wi-Fi 2.4/5GHz compatible extension cable to place the antenna in the most advantageous point in order to maximize the coverage of the radio signal. Check in advance the quality of the radio signal in the area surrounding the operating area) by monitoring the level of the Wi-Fi signal from application on Wireless Handheld. We recommend never to use the system with a Wi-Fi signal below -80dBm (a notch).

It is recommended to implement at the application level of the passive monitoring mechanisms for the radio signal in order to promptly inform the user of any limit situations via buzzer, vibrator, pop-up.



DANGER!

- It is mandatory to install the Base Station module in a cabinet which is certified with a protection degree of IP54 (or more).
- The position of the external antenna must always respect the minimum distance of 20cm from the human body for the protection of human health.



CAUTION!

- The loss, even temporary, of the Wi-Fi link causes an unintentional opening of the security relays.
- Like any Wi-Fi device, the X5 System is also sensitive to channel occupancy from the point of view of link reliability. It is the responsibility of the user to select the Wi-Fi channel to use, selecting it among the freer ones, and ensuring that the level of occupancy is preserved over time. Typically the SRD (Short Range Device) channels in the 5GHz band are the less used.

In the X5 System, the Base Station performs the function of Wi-Fi Access Point. For this purpose, some basic configurations are required:

- Definition of location in accordance with regional directives
- Choice of Wi-Fi channel
- Definition of a Safety Link password (optional)

Auxiliary functions for Pairing/Unpairing procedure:

- Pairing Lamp
- Auxiliary Unpairing Input

8.2 Configuration and programming

The Wireless Handheld and Base Station devices must be configured and programmed for use. For all details refer to JMobile Studio User Manual.

8.3 Base Station connectors and cables

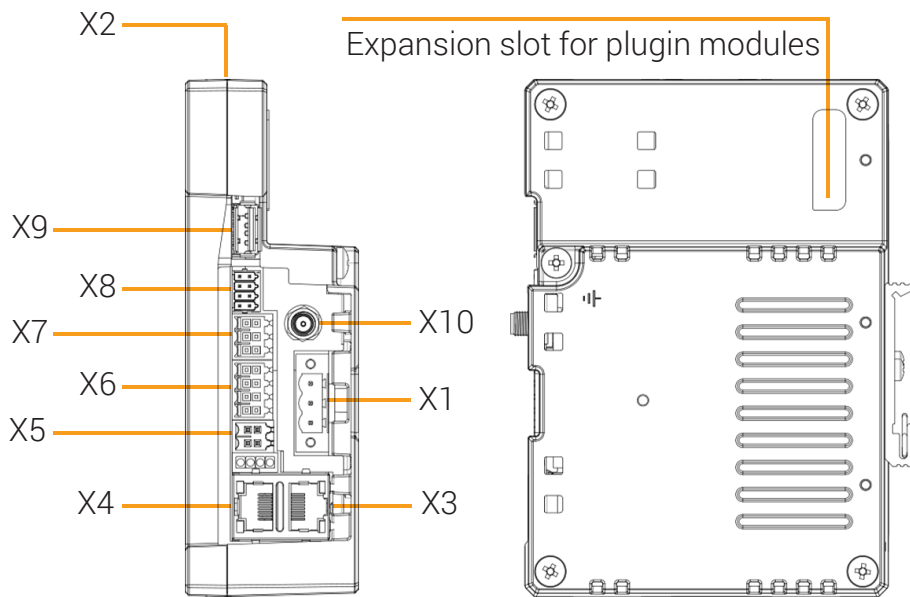

Reference	Description	Plug Connector	Cable
X1	Power Supply	Weidmüller 1944340000	AWG20, unshielded, TP
X2	SD Card	-	-
X3	Ethernet #0	RJ45 plug with latch	S/FTP Cat5e, shielded
X4	Ethernet #1	RJ45 plug with latch	S/FTP Cat5e, shielded
X5	Auxiliary I/O	Weidmüller 1277460000	AWG20, shielded
X6	Safety Outputs	Weidmüller 1727570000	AWG20, shielded
X7	Selector Outputs	Weidmüller 1727560000	AWG20, shielded
X8	Serial Port	Phoenix Contact 1715736	AWG24-20, shielded
X9	USB Port	USB A	USB 2.0, shielded
X10	Antenna	RP-SMA	Low Loss RF cable 2.4/5GHz*

*Cable as short as possible < 3m

8.3.1 General Connection Diagram

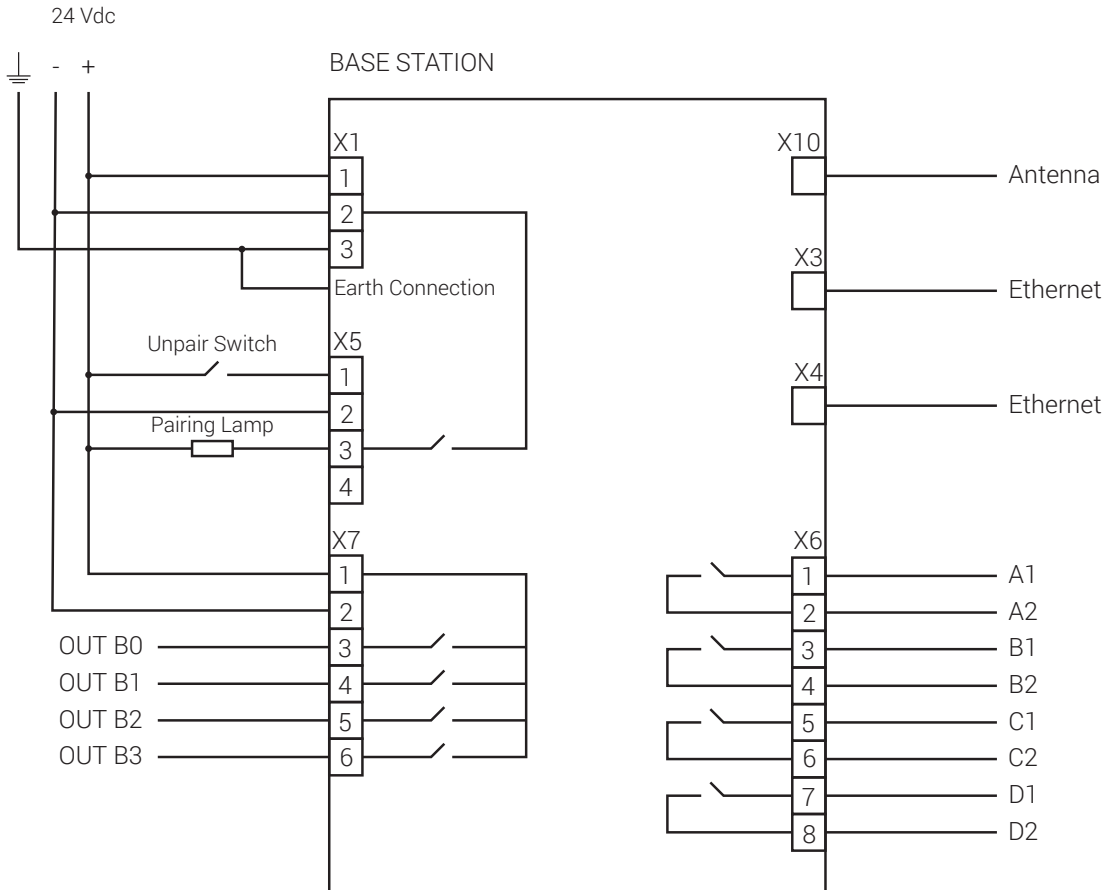
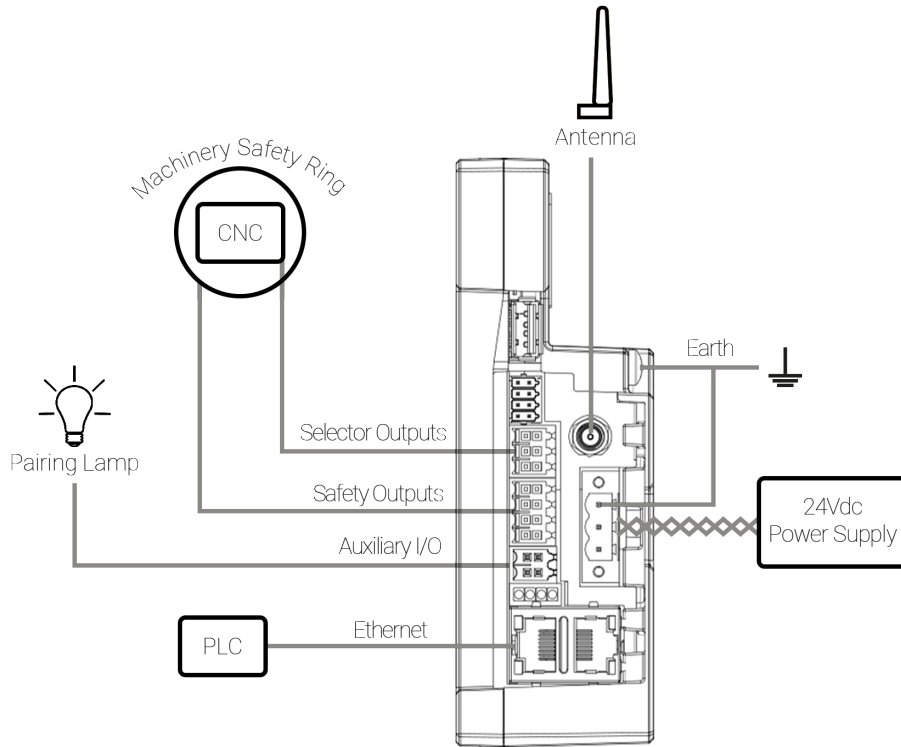

8.3.2 X1 Power Supply

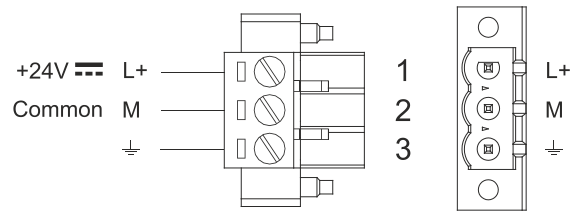

Pin	Description
1	L+
2	M
3	⏏

Power Supply Limits	Min.	Typ.	Max.
Absolute maximum	-35 V	-	35 V
Operating	10 V	24 V	32 V

8.3.3 X5 Auxiliary I/O

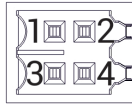

Pin	Signal	Direction	Description
1	DIGITAL_IN_P	Input	Source of auxiliary Digital Input
2	DIGITAL_IN_N	Input	Sink of auxiliary Digital Input
3	DIGITAL_OUT	Output	Pairing Lamp command
4	DIAG_OUT	Output	Diagnostic Output of safety logic

Parameter	Pin	Power Supply Limits	Condition	Min.	Typ.	Max
Differential Input Voltage	1 - 2	Absolute maximum	-	-35 V	-	35 V
Current absorbed by auxiliary Input	1 - 2	Operating	Over operating temperature range and voltage ranges	-20 mA	-	20 mA
Input voltage sensed as "Auxiliary input is OFF"	1 - 2	Operating	-	-32 V	-	5V
Input voltage sensed as "Auxiliary input is ON"	1 - 2	Operating	-	15 V	-	32 V
Voltage on the Output in the high impedance state	4	Operating	-	0 V	-	32 V
DIAG_OUT current	4	Operating	-	0 A	-	0,5 A
Voltage drop between DIGITAL_OUT and the supply ground connected to Pins 1-2 (in the low impedance state)	3	Operating	At 0,5 A, over operating temperature range and voltage	-	-	0,5 V
Leakage current of the auxiliary output (in the high impedance state)	3	Operating	Over operating temperature, voltage and current ranges	-	-	10 μ A

8.3.4 X6 Safety Outputs

The connector provides the contacts for Emergency Stop and Enabling Button contacts.



Pin	Signal	Description
1	RELAY_A1	Safety contact "A1". Emergency Stop Button contact #1
2	RELAY_A2	Safety contact "A2". Emergency Stop Button contact #1
3	RELAY_B1	Safety contact "B1". Emergency Stop Button contact #2
4	RELAY_B2	Safety contact "B2". Emergency Stop Button contact #2
5	RELAY_C1	Safety contact "C1". Enabling Button contact #1
6	RELAY_C2	Safety contact "C2". Enabling Button contact #1
7	RELAY_D1	Safety contact "D1". Enabling Button contact #2
8	RELAY_D2	Safety contact "D2". Enabling Button contact #2

Parameter	Power Supply Limits	Min.	Typ.	Max
Voltage across the safety output	Absolute maximum	-35 V	-	35 V
Current through the safety output	Absolute maximum	-0,7 A	-	-0,7 A
Voltage across the safety output	Operating	- 32 V	-	32 V
Current through the safety output	Operating	- 0,5 A	-	0,5 A

8.3.5 X7 Selector Outputs



Pin	Signal	Direction	Description
1	+VBB	-	Source of Solid State Outputs
2	GND_BB	-	Sink of Solid State Outputs
3	SS_OUT_B0	Output	Selector OUT – B0
4	SS_OUT_B1	Output	Selector OUT – B1
5	SS_OUT_B2	Output	Selector OUT – B2
6	SS_OUT_B3	Output	Selector OUT – B3

Parameter	Pin	Power Supply Limits	Min.	Typ.	Max
Supply voltage applied for contact	1 - 2	Absolute maximum	-35 V	-	35 V
Supply voltage applied for contact	3 - 4 5 - 6	Operating	10 V	24 V	32 V
Current coming out from safety output (in the low impedance state)	3 - 4 5 - 6	Operating	0	-	0,5 A

8.3.6 X8 Serial Port

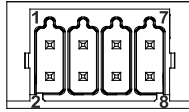

RS-232	
Pin	Description
1	RX
2	TX
3	CTS
4	RTS
5	+5V Output at 100 mA max.
6	GND
7	
8	SHIELD

RS-422, RS-485	
Pin	Description
1	CHB-
2	CHA-
3	CHB+
4	CHA+
5	+5V Output at 100 mA max.
6	GND
7	
8	SHIELD

To operate in RS-485 pins 1-2 and 4-3 must be connected externally.

9 Environmentally-friendly disposal

All components related to the Wireless Handheld and Base Station are designed to respect the environment and reduce as much as possible the impact on pollution. It is important to specify how to dismiss the different components of the X5 System in order to have an environmentally-friendly recycling process.

Component	Disposal
Cables Battery Electronic boards	Electronic recycling
Paper packaging	Paper recycling
Plastic packaging	Plastic recycling

10 Standards and Certifications

10.1 EC directives

Directive	Description
2006/42/EC	Machine Directive
2014/30/EU	Electromagnetic Compatibility Directive (EMC)
2014/53/EU	Harmonisation of the laws of the Member States relating to the making available on the market of radio equipment and repealing Directive 1999/5/EC

10.2 International standards

Safety of machinery	
EN ISO 13849-1:2015	Safety of Machinery – Safety related parts of control systems Part 1: General principles for design
EN ISO 13849-2:2012	Safety of Machinery – Safety related parts of control systems Part 2: Validation
EN 61010-1: 2010 + A1:2019 + AC:2019-04	Safety requirements for electrical equipment for measurement, control, and laboratory use
EN IEC 61010-2-201: 2018	Safety requirements for electrical equipment for measurement, control and laboratory use - Part 2-201: Particular requirements for control equipment
EMC	
EN 61000-6-2:2017	Electromagnetic Compatibility (EMC) Part 6-2: Generic Standards – Immunity for Industrial Environments
EN 61000-6-4:2007+A1:2011	Electromagnetic Compatibility (EMC) Part 6-4: Generic Standards – Emission Standard for Industrial Environments
EN 61000-4-2:2009	Electromagnetic compatibility (EMC) Part 4-2: Testing and measurement techniques Electrostatic discharge immunity test
EN 61000-4-3:2006+A2:2010	Electromagnetic compatibility (EMC) Part 4-3: Testing and measurement techniques Radiated, radio-frequency, electromagnetic field immunity test
EN 61000-4-4:2012	Electromagnetic compatibility (EMC) - Part 4-4: Testing and measurement techniques - Electrical fast transient/burst immunity test
EN 61000-4-5:2006	Electromagnetic compatibility (EMC) Part 4-3: Testing and measurement techniques Radiated, radio-frequency, electromagnetic field immunity test
EN 61000-4-6:2009	Electromagnetic compatibility (EMC) Part 4-6: Testing and measurement techniques - Immunity to conducted disturbances, induced by radio-frequency fields
EN 61000-4-8:2013	Electromagnetic compatibility (EMC) - Part 4-8: Testing and measurement techniques Power frequency magnetic field immunity test
EN 61000-4-29:2000	Electromagnetic compatibility (EMC) - Part 4-29: Testing and measurement techniques - Voltage dips, short interruptions and voltage variations on d.c. input power port immunity tests
ETSI EN 300 328 V2.1.1:2016	Wideband transmission systems; Data transmission equipment operating in the 2,4 GHz ISM band and using wide band modulation techniques; Harmonised Standard covering the essential requirements of article 3.2 of Directive 2014/53/EU
ETSI EN 301 893 V2.1.1:2017	5 GHz RLAN; Harmonised Standard covering the essential requirements of article 3.2 of Directive 2014/53/EU
ETSI EN 300 330 V2.1.1:2017	Short Range Devices (SRD); Radio equipment in the frequency range 9 kHz to 25 MHz and inductive loop systems in the frequency range 9 kHz to 30 MHz; Harmonised Standard covering the essential requirements of article 3.2 of Directive 2014/53/EU
EN 62311:2008	Assessment of electronic and electrical equipment related to human exposure restrictions for electromagnetic fields (0 Hz - 300 GHz)
ETSI EN 301489-1 V2.1.1	Electromagnetic compatibility and Radio spectrum Matters (ERM) – Electromagnetic Compatibility (EMC) standard for radio equipment and services – Part1: Common technical requirements
ETSI EN301489-17 V3.1.1	Electromagnetic compatibility and Radio spectrum Matters (ERM) – Electromagnetic Compatibility (EMC) standard for radio equipment and services – Part17: Specific conditions for broadband data transmission system
EN 55011:2007	Industrial, scientific and medical (ISM) radio-frequency equipment - Electromagnetic disturbance characteristics - Limits and methods of measurement

Degrees of protection and environmental tests

EN 60529:1991 + AC:1993 + A1:2000 + A2:2013 + AC:2016 + AC:2019	Degrees of protection provided by enclosures (IP code)
EN 60068-2-1:2007	Environmental testing Part 2-1:Tests – TestA: Cold
EN 60068-2-2:2007	Environmental testing Part 2-2:Tests – TestB: Dry heat
EN 60068-2-6:2008	Environmental testing Part 2-6:Tests – TestFc: Vibration (sinusoidal)
EN 60068-2-30:2005	Environmental testing Part 2-30:Tests – TestDb: Damp heat, cyclic (12h+ 12h cycle)
IEC 61131-2:2017 cl. 5.3.4	Programmable controllers – Part2: Equipment requirements and tests, § 5.3.4: Free falls (according EN 60068-2-31, free fall, procedure 1.)
EN 61131-2:2017 cl. 5.3.3	Programmable controllers – Part2: Equipment requirements and tests, § 5.3.3: Shock (according EN 60068-2-27)

Emergency Stop Button conforming to

EN 60947-5-1:2004/A1:2009	Low-voltage switchgear and controlgear
EN 60947-5-5:1997/A11:2013	Low-voltage switchgear and controlgear
EN 13850:2015	Safety of machinery - Emergency stop - Principles for design
EN 60204-1:2010	Safety of machinery. Electrical equipment of machines

Enabling Button conforming to

IEC 60947-5-1	Low-voltage switchgear and controlgear - Part 5-1: Control circuit devices and switching elements - Electromechanical control circuit devices
EN 60947-5-1	Low-voltage switchgear and controlgear - Part 5-1: Control circuit devices and switching elements - Electromechanical control circuit devices
UL508	Industrial Control Equipment.
CSA C22.2 N°14	Industrial Control Equipment.
IEC 60947-5-8:2006	Low-voltage switchgear and controlgear - Part 5-8: Control circuit devices and switching elements - Three-position enabling switches

11 Special Instruction for Use

- The equipment shall only be used in an area of not more than pollution degree 2, as defined in IEC/EN 60664-1
- Care shall be taken not to allow layers of dust to form on the graphic panel in a way that might cause the accumulation of static charges. Keep the faceplate of the HMI device clean: the equipment must be cleaned only with a soft cloth and neutral soap product. Do not use solvents.
- This device should not be used for purposes and methods other than indicated in this document and in the documentation accompanying the product.

12 Unpacking and Packing Instructions

- Unpacking

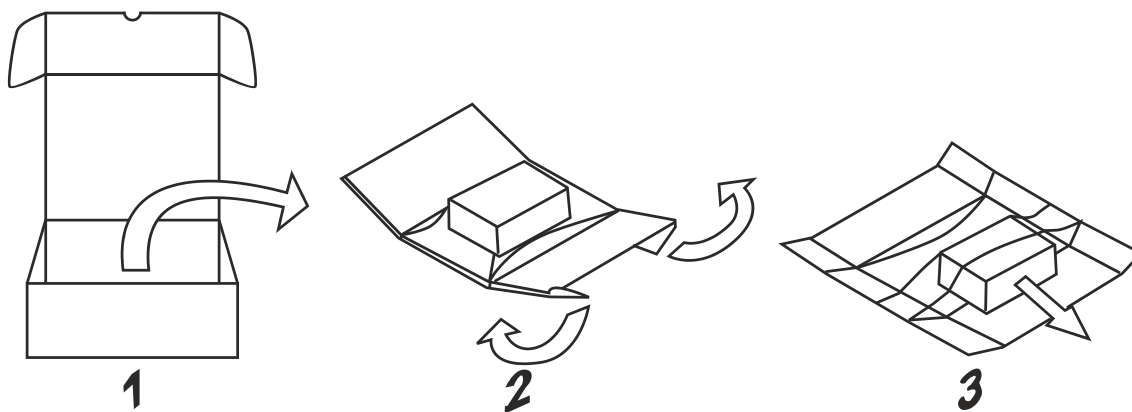

- To repack the units, please follow the instructions backwards.