

## I ES716-2GS

### Managed Industrial Ethernet Switch

#### User manual

#### 【Summarize】

I ES716-2GS is an industrial grade, managed and redundancy Ethernet switch. The industrial Ethernet switch consists of 4 Ethernet ports and 2 gigabit (SFP slot) ports. It provides an economical solution for your industrial Ethernet connection. It supports auto flow control, full/half duplex mode and MDI/MDI-X self-adaption.

SW-Ring<sup>TM</sup> is designed as rapid redundancy network arithmetic. It provided recover technology for fault of rapid redundant network, the recovery time<20ms. Product accorded to CE, FCC standard and Industry grade 4 design requirement, support redundancy power input and 1 channel relay alarm output, and -40~75℃ working temperature, can meet all kinds of Industrial environment requirement. It can use in power, water conservancy, transportation area etc.

#### 【Packing list】

Please check the packaging and accessories by your first using.

- Industrial Ethernet switch × 1
- User manual × 1
- CD × 1
- Certificate of quality × 1
- Warranty card × 1

Please inform us or our distributor if your equipments have been damaged or lost any accessories, we will try our best to satisfy you.

#### 【Feature】

##### High performance network exchange technology

- Support IEEE802.3, IEEE802.3u, IEEE 802.3x, IEEE802.3z, IEEE802.1Q, IEEE802.1p, IEEE802.1W
- SW-Ring ring network patent technology (Fault recovery time<20ms)
- Support RSTP, way exchange time<50ms

- Support WEB configuration
- Support IGMP snooping
- Support configuration file up and download
- Support SNMP, QOS, port trunking, port mirroring function
- Support Port based VLAN and IEEE 802.1Q VLAN
- Store and Forward switching process type
- Support port status display, data update.
- Support MAC address auto-learning, auto-aging
- Support 8K MAC address
- Support 7.6Gbps backboard bandwidth
- Support redundancy power supply(12~48VDC)
- Support 1 channel relay alarm output

##### Reliable Industrial grade design

- Industrial grade 4 design, -40-75℃ work temperature
- No fan deign
- IP40 protection grade
- DIN rail

#### 【Panel layout】

##### I ES716-2GS

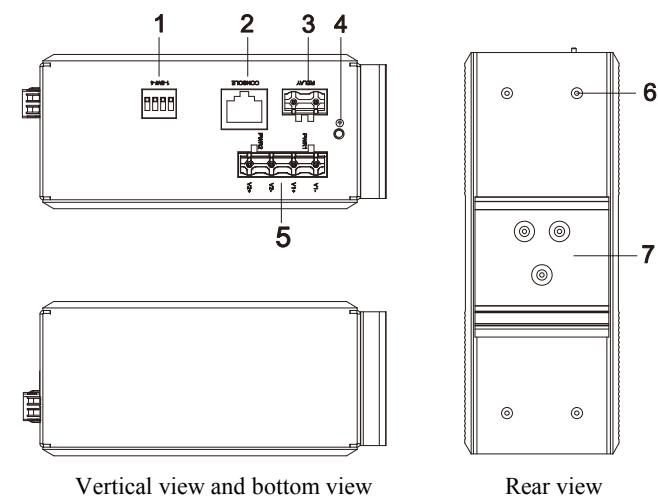

Vertical view and bottom view

Rear view

- 1、DIP switch
- 2、Console port
- 3、Relay alarm output
- 4、Ground screw(Protect ground)
- 5、4 bit power input terminal block
- 6、Screw holes for Wall Mounting Kit
- 7、Din-Rail mount
- 8、Power indicator (P1/P2)
- 9、System running indicator
- 10、Relay alarm LED
- 11、Fast Ethernet port connection indicator
- 12、Fiber port connection indicator(G1/G2)
- 13、1000Base-X SFP fiber port
- 14、10/100BaseT(X) (RJ45) ports

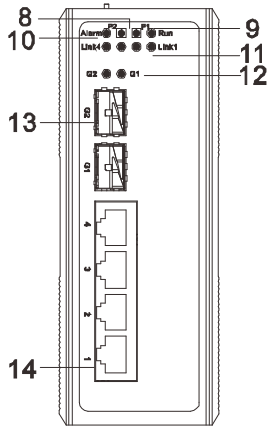

system, use 1 pair terminal block connect the device at the same time. If one of the power systems broke, the device can work un-interruptible. Built-in overcorrect protection, Reverse connection protection. Voltage input range is 12 ~ 48VDC (terminal block defined as: V1-, V1+, V2-, V2+).

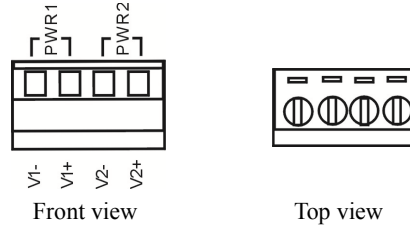

Important notice:

1. Power ON operation: first of all, insert power cable's terminal block into device's power port, then insert power supply plug into power source
2. Power OFF operation: First off all, unpin power plug, then strike the terminal block, please take care of operation sequence.

### 【Relay connection】



Relay access terminals in the top panel of the device. The relay is open state in normal non alarm state, when there is any alarm information to the closed state. The two terminal block connector are used to detect both power failure and port failure. The two wires attached to the Fault contacts form a close circuit when the device has lost power supply from one of the DC power inputs or one of the ports is failure.

### 【Console port】

The product provided 1pcs procedure test port based in serial port. It adopts RJ45 interface, located in top panel, can configure related command through RJ45 to DB9 female cable.

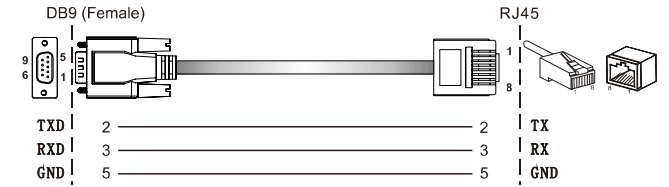

### 【DIP switch】



Top panel provided 4 bits DIP switch to do function configure (OFF is default factory) .1 is keep for future function. 2 is recovery default factory. 3 is for upgrade. 4 keep for future function. Please power off and power on when you change the status of DIP switch.

### 【Communication connector】

#### 10/100BaseT(X) Ethernet port

The pinout of RJ45 port display as below, connect by UTP or STP. The connect distance is no more than 100m. 100Mbps is used 120Ω of UTP 5; 10Mbps is used 120Ω of UTP 3, 4, 5.

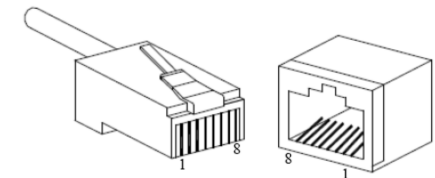

RJ 45 port support automatic MDI/MDI-X operation. Can connect the PC, Server, Converter and HUB .Pin 1,2,3,6 Corresponding connections in MDI. 1→3, 2→6, 3→1, 6→2 are used as cross wiring in the MDI-X port of Converter and HUB. 10Base-T/100Base-TX are used in MDI/MDI-X, the define of Pin in the table as below.

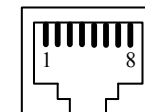

### 【Dimension】

Unit (mm)

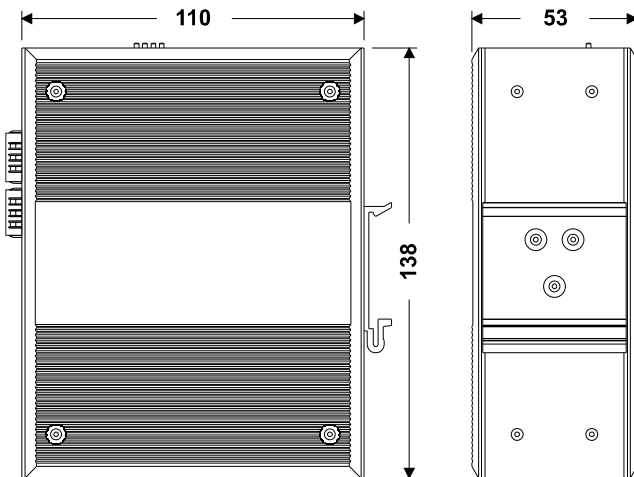

### 【Power supply input】

IES716-2GS top panel provided 4 bit power supply input terminal block, support DC input. DC power supply input supported redundancy function, provided PWR1 and PWR2 power input, can use for single, and can connect 2 separately power supply

NO.	MDI signal	MDI-X signal
1	TX+	RX+
2	TX-	RX-
3	RX+	TX+
6	RX-	TX-
4, 5, 7, 8	—	—

Note: "TX±" Transmit Data±, "RX±" Receive Data±, "—" Not Use.

### MDI (straight-through cable)

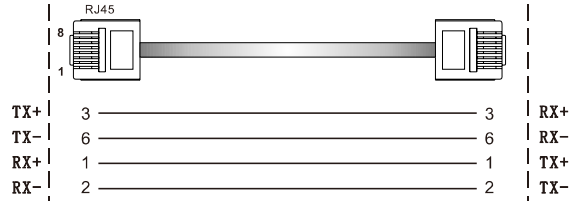

### MDI-X (Cross over cable)

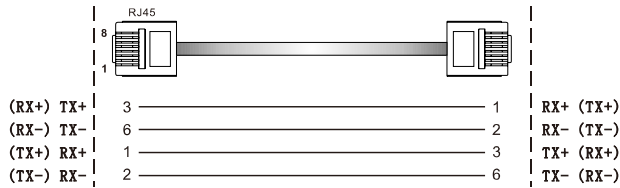

MDI/MDI-X auto connection makes switch easy to use for customers without considering the type of network cable.

### 1000SFP fiber port(mini-GBIC)

1000BaseSFP fiber port adopts gigabit mini-GBIC transmission, can choice different SFP module according to different transfer distance. Fiber interface must use for pair, TX port is transmit side, must connect to RX (receive side). The fiber interface support loss line indicator.

**Suppose:** If you make your own cable, we suggest labeling the two sides of the same line with the same letter (A-to-A and B-to-B, shown as below, or A1-to-A2 and B1-to-B2).

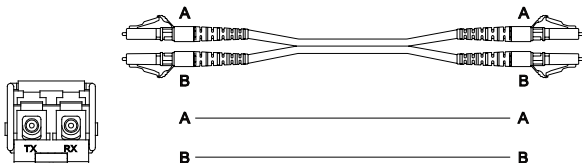

### 【LED Indicator】

LED indicator light on the front panel of product, the function of each LED is described in the table as below.

System Indication LED		
LED	State	Description
<b>PWR</b> (P1, P2)	ON	Power is being supplied to power input PWR input
	OFF	Power is <b>not</b> being supplied to power input PWR input
<b>RUN</b>	ON/OFF	System is not running well
	Blinking	System is running well
<b>Link/ACT</b> (1~4/G1~G2)	ON	Port connection is active
	Blinking	Data transmitted
	OFF	Port connection is not active
<b>ALARM</b>	ON	Has alarm information
	OFF	No alarm information

### 【Installation】

Before installation, confirm that the work environment meet the installation require, including the power needs and abundant space. Whether it is close to the connection equipment and other equipments are prepared or not.

1. Avoid in the sunshine, keep away from the heat fountainhead or the area where in intense EMI.
2. Examine the cables and plugs that installation requirements.
3. Examine whether the cables be seemly or not (less than 100m) according to reasonable scheme.
4. Power: 12~48VDC power input
5. Environment: working temperature -40~75°C  
Storage Temperature: -40~85°C  
Relative humidity 5%~95%

### DIN-rail installation

In order to apply for industrial environments conveniently, IES716-2GS adopts 35mm DIN-Rail installation, the installation

steps are as follows:

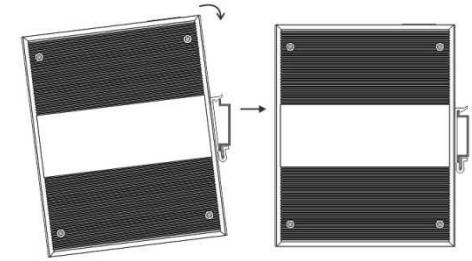

1. Examine the DIN-Rail accessories
2. Examine DIN Rail is firm or not and the position is suitable or not.
3. Insert the top of the DIN-Rail into the slot just below the stiff metal spring.
4. The DIN-Rail attachment unit will snap into place as shown below.

### Wiring Requirements

Cable laying need to meet the following requirements,

1. It is needed to check whether the type, quantity and specification of cable match the requirement before cable laying;
2. It is needed to check the cable is damaged or not, factory records and quality assurance booklet before cable laying;
3. The required cable specification, quantity, direction and laying position need to match construction requirements, and cable length depends on actual position;
4. All the cable cannot have break-down and terminal in the middle;
5. Cables should be straight in the hallways and turning;
6. Cable should be straight in the groove, and cannot beyond the groove in case of holding back the inlet and outlet holes. Cables should be banded and fixed when they are out of the groove;
7. User cable should be separated from the power lines.

Cables, power lines and grounding lines cannot be overlapped and mixed when they are in the same groove road. When cable is too long, it cannot hold down other cable, but structure in the middle of alignment rack;

8. Pigtail cannot be tied and swerved as less as possible. Swerving radius cannot be too small (small swerving causes terrible loss of link). Its banding should be moderate, not too tight, and should be separated from other cables;

9. It should have corresponding simple signal at both sides of the cable for maintaining.

## 【Specification】

### Technology

Standard: Support IEEE802.3, IEEE802.3u, IEEE802.3x, IEEE802.3z, IEEE802.1Q, IEEE802.1p, IEEE802.1W

Flow control: IEEE802.3x flow control, back press flow control

### Function

Switch function: SW-Ring, QOS, 802.1QVLAN, RSTP, SNMP, Port trunking, static multicast filter, port mirroring, bandwidth management, broadcast storm control, port flow statistics, upgrade online, up and download configuration file, user name access system

SW-Ring: Support Single, Couple, Chain, Dual homing

### Exchange attribute

100M forward speed: 148810pps

1000M forward speed: 1488100pps

100M maximum filter speed: 148810pps

1000M maximum filter speed: 1488100pps

Transmit mode: store and forward

System exchange bandwidth: 7.6G

MAC address table: 8K

Memory: 1M

### Interface

Electric port: 10Base-T/100Base-TX auto speed control, Half/full duplex and MDI/MDI-X auto detect

1000M fiber port: 1000Base-FX (LC interface)

Console port: debug serial port carry out CLI command

Alarm port: 2 bit terminal block

1 channel relay alarm output

### Transfer distance:

Twisted cable: 100M ( standard CAT5/CAT5e cable)

Multi-mode: 1310nm, 2Km

Single-mode: 1310nm, 20/40/60Km

1550nm, 80/100/120Km

### LED indicator:

Run indicator: Run

Interface indicator: Link (1~4/G1~G2)

Power supply indicator: PWR (P1, P2)

### Power supply

Input voltage: 12~48VDC

Type of input: 4 bit terminal block

Overload Current Protection: 4.0A

Support DC dual power supply alarm input

Support DC dual power supply redundancy

### Consumption

Unload consumption: 2.2W@24VDC

Full load consumption: 5.5W@24VDC

### Working environment:

Working temperature: -40~75℃

Storage temperature:-40~85℃

Relative Humidity: 5%~95% (no condensation)

### Mechanical Structure:

Shell: IP40 protect grade, metal shell

Installation: DIN rail

Size (W×H×D) : 53mm×138mm×110mm

### Industry Standard:

EMI: FCC Part 15, CISPR (EN55022) class A

EMS: EN61000-4-2 (ESD), Level 4

EN61000-4-3 (RS), Level 3

EN61000-4-4 (EFT), Level 4

EN61000-4-6 (CS), Level 3

EN61000-4-8, Level 5

Shock: IEC 60068-2-27

Free fall: IEC 60068-2-32

Vibration: IEC 60068-2-6

### Certification

CE, FCC, RoHS, UL508 (Pending)

**Warranty:** 5 years