

IES215 Series Industrial Ethernet switch User manual

【Summarize】

The IES215 series switch is a type of unmanaged industrial Ethernet switch. The industrial Ethernet switch consists of 5 Fast Ethernet ports. The switch can maximum support two interface type optional that Fast Ethernet copper ports and optical fiber port. The switch supports IEEE802.3, IEEE802.3u and IEEE802.3x standard. IP40 grade protection ensures reliable work in terrible environment. LED indicator is helpful to monitor and control the status of network connection. The switch with DC series and AC series of two type power supply products can be optional. It complies with FCC, CE standard. DIN-rail installation and wide operating temperature (-40~75℃), can satisfied some kinds of industrial environment, can provide reliable and quickly solution for your Ethernet device.

【Packing list】

The industrial Ethernet switch is shipped with the following items. If any of these items are missing or damaged, please contact your customer service representative for assistance.

- Industrial Ethernet switch × 1
- User manual × 1
- DIN-Rail mounting kit × 1
- Warranty card × 1
- Certificate of quality × 1

【Feature】

- Support IEEE802.3/802.3u/802.3x, store and forward
- Support 5 Fast Ethernet
- RJ45 Support 10/100M, half/full duplex, MDI/MDI-X
- Support -40~75℃ working temperature
- DC series support 9~48VDC power input,
AC series support 100~240VAC power input
- Industrial grade, IP40 protection, metal shell
- DIN Rail installation

【Panel layout】

1. Ground screw
2. Power input terminal block
3. DIP switch

4. DIN-Rail mounting kit
5. Power indicator
6. Ethernet port link/act indicator
7. 10/100Base-T(X) (RJ45) port
8. 100Base-FX (SC/FC/ST) fiber port

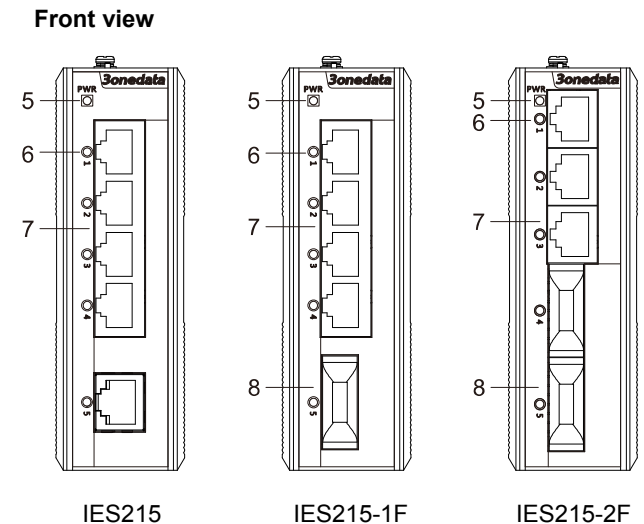
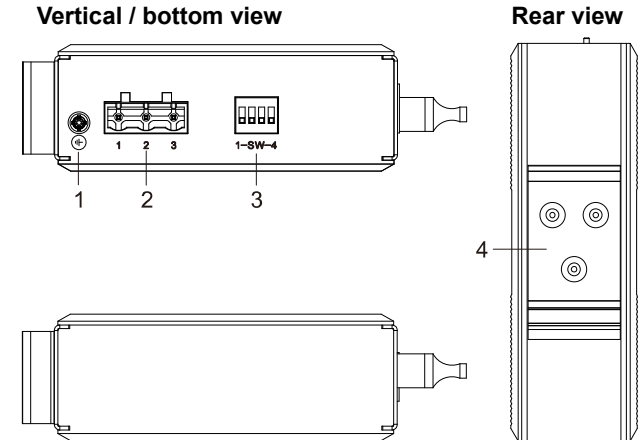

【Power supply input】

The Industrial Ethernet switches have single power and redundancy power two kinds of power input.

DC Series Switch:

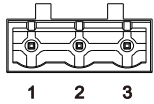

The switch top panel provided 3 bit power supply input terminal block, support DC input. Reverse connection protection. Voltage input range is 9~48VDC (terminal block defined as, 1: V+, 2: FG, 3: V-).

AC Series Switch:

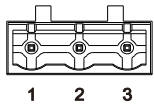

The single power AC series top panel provides 3 bit terminal block for 100~240VAC power input (1: L/+, 2: FG, 3: N/-)

Important notice:

1. Power ON operation: first of all, insert power cable's terminal block into device's power port, then insert power supply plug into power source.
2. Power OFF operation: First off all, unpin power plug, then strike the terminal block, please take care of operation sequence.

【DIP Switch】



Top panel provided 4 bits DIP switch to do function configure (ON to enable effective). 1 is RJ45 port support pause frame flow control and the optic fiber port support back press flow control. 2 is RJ45 force 10M. 3 and 4 is reserved.

【Dimension】

The series of products are the same size, and the number of interface is different.

Unit (mm)

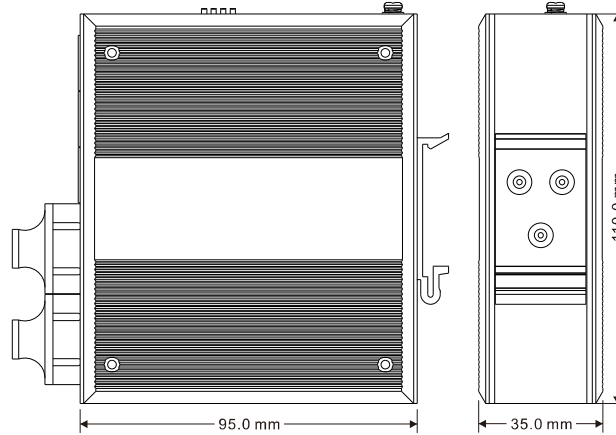

【Communication connector】

10/100BaseT(X) Ethernet port

The pinout define of RJ45 port display as below, connect by UTP or STP. The connect distance is no more than 100m. 100Mbps is used 120Ω of UTP 5, 10Mbps is used 120Ω of UTP 3, 4, 5.

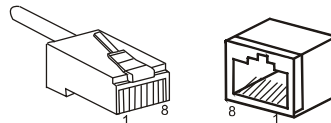

RJ 45 port support automatic MDI/MDI-X operation. Can connect the PC, Server, Converter and HUB .Pin 1,2,3,6 Corresponding connections in MDI. 1→3, 2→6, 3→1, 6→2 are used as cross wiring in the MDI-X port of Converter and HUB. 10Base-T/100Base-TX are used in MDI/MDI-X, the define of Pin in the table as below.

NO.	MDI signal	MDI-X signal
1	TX+	RX+
2	TX-	RX-
3	RX+	TX+
6	RX-	TX-
4, 5, 7, 8	—	—

Note: , "TX±"transmit data±, "RX±"receive data±, "—"not use.

10/100Base-T(X) MDI (straight-through cable)

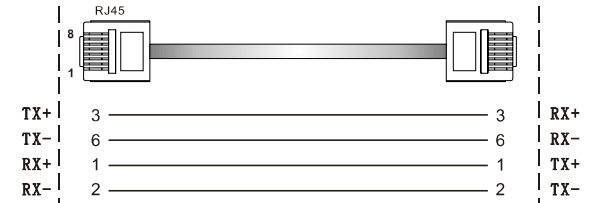

10/100Base-T(X) MDI-X (Cross over cable)

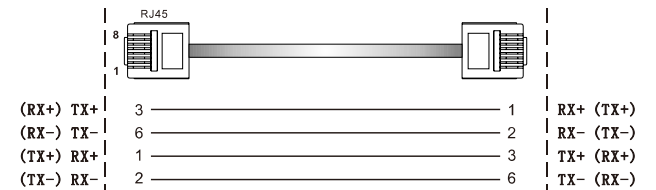

MDI/MDI-X auto connection makes switch easy to use for customers without considering the type of network cable.

100Base-FX SC/ST/FC port

100Base-FX port support full-duplex SC/ST/FC Multi mode or Single mode. The fiber port TX(transmit) connect remote RX(receive).

Suppose: If you make your own cable, we suggest labeling the two sides of the same line with the same letter (A-to-A and B-to-B, shown as below, or A1-to-A2 and B1-to-B2).

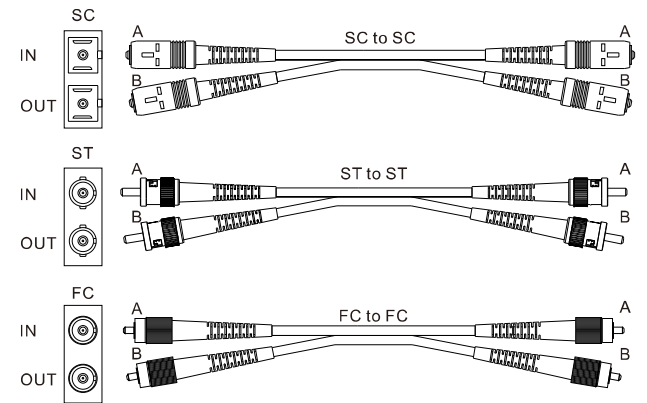

【LED Indicator】

LED indicator light on the front panel of product, the function of each LED is described in the table as below.

LED system status		
LED	Status	Description
PWR	ON	PWR connect and running normal
	OFF	Power supply have no connection or unwanted
Link/ACT (1~5)	ON	Port made effective connection
	Blinking	Port is in active status
	OFF	Port did not make effective connection

【Installation】

Before installation, confirm that the work environment meet the installation require, including the power needs and abundant space. Whether it is close to the connection equipment and other equipments are prepared or not.

1. Avoid in the sunshine, keep away from the heat fountainhead or the area where in intense EMI.
2. Examine the cables and plugs that installation requirements.
3. Examine whether the cables be seemly or not (less than 100m) according to reasonable scheme.
4. Power:
DC series product support 9~48VDC power supply;
AC series product support 100~240VAC power supply;
5. Environment: working temperature: -40~75℃
Storage Temperature: -40~85℃
Relative humidity 5%~95%

DIN Rail Installation

In order to use in industrial environments expediently, the product adopt 35mm DIN-Rail installation, the installation steps as below:

1. Examine the DIN-Rail attachment
2. Examine DIN Rail whether be firm and the position is suitability or not.
3. Insert the top of the DIN-Rail into the slot just below the stiff metal spring.
4. The DIN-Rail attachment unit will snap into place as shown below.

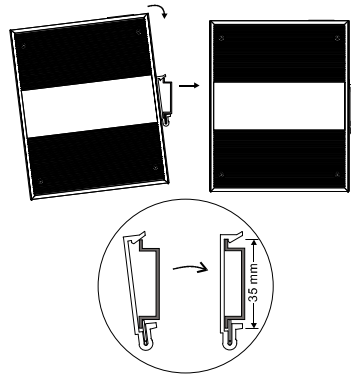

Wiring Requirements

Cable laying need to meet the following requirements,

1. It is needed to check whether the type, quantity and specification of cable match the requirement before cable laying;
2. It is needed to check the cable is damaged or not, factory records and quality assurance booklet before cable laying;
3. The required cable specification, quantity, direction and laying position need to match construction requirements, and cable length depends on actual position;
4. All the cable cannot have break-down and terminal in the middle;
5. Cables should be straight in the hallways and turning;
6. Cable should be straight in the groove, and cannot beyond the groove in case of holding back the inlet and outlet holes. Cables should be banded and fixed when they are out of the groove;
7. User cable should be separated from the power lines. Cables, power lines and grounding lines cannot be overlapped and mixed when they are in the same groove road. When cable is too long, it cannot hold down other cable, but structure in the middle of alignment rack;
8. Pigtail cannot be tied and swerved as less as possible. Swerving radius cannot be too small (small swerving causes terrible loss of link). Its banding should be moderate, not too tight, and should be separated from other cables;

9. It should have corresponding simple signal at both sides of the cable for maintaining.

【Specification】

Technology

Standard: Support IEEE802.3, IEEE802.3u, IEEE802.3x
Flow control: IEEE802.3x flow control, back press flow control

Exchange attribute

100M forward speed: 148810pps
Transmit mode: store and forward
System exchange bandwidth: 1.6G
MAC address table: 2K

Interface

RJ45 port: 10Base-T/100Base-TX auto speed control,
Half/full duplex and MDI/MDI-X auto detect
Fiber port: 100Base-FX, SC/FC/ST optional

Transfer distance

Twisted cable: 100M (standard CAT5/CAT5e cable)
Multi-mode: 1310nm, 2Km
Single-mode: 1310nm, 20/40/60Km;
1550nm, 80/100/120Km

Power supply

- DC series switch
Input voltage: 9~48VDC
Support opposite connection protection
Type of input: 3 bit 7.62mm pitch terminal block
- AC Series switch
Input voltage: 100~240VAC
Type of input: 3 bit 7.62mm pitch terminal block

Consumption

- IES215-P (9~48VDC):
Unload consumption: 0.96W@48VDC
Full load consumption: 2.45W@48VDC
- IES215-P (100~240VAC):
Unload consumption: 0.8W@220VAC
Full load consumption: 2.4W@220VAC
- IES215-1F-P (9~48VDC):

Unload consumption: 2.69W@48VDC

Full load consumption: 3.70W@48VDC

➤ IES215-1F-P (100~240VAC):

Unload consumption: 1.6W@220VAC

Full load consumption: 2.3W@220VAC

➤ IES215-2F-P (9~48VDC):

Unload consumption: 2.64W@48VDC

Full load consumption: 3.36W@48VDC

➤ IES215-2F-P (100~240VAC):

Unload consumption: 2.6W@220VAC

Full load consumption: 3.7W@220VAC

Working environment

Working temperature: -40~75°C

Storage temperature: -40~85°C

Relative Humidity: 5%~95% (no condensation)

Mechanical Structure

Shell: IP40 protect grade, metal shell

Installation: DIN-Rail mounting

Weight: 0.34kg (IES215)

0.35kg (IES215-1F)

0.36kg (IES215-2F)

Size (W×H×D): 35mm×110mm×95mm

Industry Standard

EMI: FCC Part 15, CISPR (EN55022) class A

EMS: EN 61000-4-2 (ESD) Level 3

EN 61000-4-4 (EFT) Level 3

EN 61000-4-5 (Surge) Level 3

Shock: IEC 60068-2-27

Free fall: IEC 60068-2-32

Vibration: IEC 60068-2-6

Certification

CE, FCC, RoHS, UL508 (Pending)

Warranty: 5 years